

COURSE GUIDE

EDU 250 BIOLOGY METHODS

Course Team: Professor Uchenna Mariestella Nzewi (Course Developer) – Department of Science Education University of Nigeria, Nsukka
(Course Writers) Professor Uchenna Nzewi – UNN
Dr. Appollonia Nwosu – UNN Dr. Nkadi Onyegegbu – UNN
Dr. Chinwe Nwagbo – UNN
Dr. Loretta Nworgu – UNN
Dr. Timothy James (Programme Leader) – NOUN
Dr. Femi A. Adeoye (Course Coordinator) – NOUN
Prof. Chibuogwu V. Nnaka (Course reviewers) – NOUN



NATIONAL OPEN UNIVERSITY OF NIGERIA

© 2022 by NOUN Press
National Open University of Nigeria
Headquarters
University Village
Plot 91, Cadastral Zone
Nnamdi Azikiwe Expressway
Jabi, Abuja

Lagos Office
14/16 Ahmadu Bello Way
Victoria Island, Lagos

e-mail: centralinfo@nou.edu.ng

URL: www.nou.edu.ng

All rights reserved. No part of this book may be reproduced, in any form or by any means, without permission in writing from the publisher.

Printed 2019, 2022

ISBN: 978-058-738-1

CONTENTS

CONTENTS

Introduction.....	iv
What you will learn in this Course.....	iv
Course Aims.....	iv
Course Objectives.....	v
Working Through This Course.....	v
Course Materials.....	v
Study Units.....	vi
Textbooks and References.....	vi
Assessment.....	vii
Tutor Marked Assignment (TMA)	vii
Final Examination and Grading	viii
Course Marking Scheme	viii
Course Overview.....	viii
How to Get the Best From This Course.....	ix
Facilitators/Tutors and Tutorials.....	xi
Summary.....	xii

Introduction

This course is a 2-unit second year course. The course is available to all students who are registered for the BSc or MSc degree in Biology Education. The course will also be suitable for practicing biology teachers who want to update their teaching skills.

The course consists of 15 units arranged under 4 modules and will involve methods and techniques of teaching biology, resources for teaching biology, planning for biology teaching, laboratory design, management and safety, and evaluation in Biology teaching.

There are no compulsory pre-requisites for this course. It is expected that before you register for this course, you must have taken all the first year courses and some of the second year courses. This will give you enough content background to enable you appreciate and apply the methods being discussed here. If you are a practicing teacher, you can start the course any time because you are already familiar with the contents you are expected to teach.

This course guide tells you briefly, what the course is about, what course materials you will be using and how you can work your way through these materials.

What You Will Learn in this Course

During the course, you will learn the basic methods of teaching and learning biology, resources for teaching biology, planning for biology teaching, the laboratory in biology teaching, and methods of evaluating learning outcomes in biology.

Course Aims

The overall aims of this course are to:

- introduce you to the basic methods and techniques of teaching biology,
- familiarize you with the resources for teaching biology,
- expose you to the need for proper planning before embarking on teaching any topic in biology,
- explain to you how to make appropriate use of the laboratory in teaching biology, and
- teach you the various tools and techniques for assessing learning outcomes in biology.

Course Objectives

To achieve the aims set out above, the course sets out overall objectives. In addition, each of the fifteen units has its specific objectives. The unit objectives are included at the beginning of each unit. You should read them before you start working through the unit and bear them in mind as you go through the unit. You are encouraged to refer to them as you work through the unit. You should in addition always look at the unit objectives after completing a unit. In this way, you can be sure that you have done what was required of you by the unit. The wider objectives of this course are set out below.

On the successful completion of this course, you should be able to:

1. Discuss the traditional methods of teaching biology.
2. List and explain the modern techniques of teaching biology
3. Identify and use different resources for teaching biology
4. Select good textbooks for use in biology classrooms
5. Improvise teaching materials where the original ones are not available Prepare good teaching units and lesson plans
6. Discuss the role of the laboratory in biology teaching
7. Manage a biology laboratory effectively
8. Apply good safety measures in the laboratory
9. Describe the various evaluation techniques that can be used to evaluate learning outcomes in biology
10. Produce and use various tools and techniques in evaluating learning outcomes.

Working through this Course

To complete this course, you are required to read the study units, read the recommended texts and other reading materials that are provided or recommended. You will also carry out the exercises and practical activities recommended within the course units. Each unit contains self-assessment exercises, and at stipulated points in the course, you are required to submit assignments for assessment purposes. The course should take you between 55-60 weeks to complete. At the end of the course, you will be required to write a final examination.

Major components of the course are;

1. Course Guide
2. Study Units
3. Textbooks
4. Course Materials

Study Units

There are four modules and fifteen units in the course. The breakdown is as follows:

Module 1 Methods and Techniques of Teaching Biology

- Unit 1 Traditional Methods of Teaching Biology
- Unit 2 Demonstration and Experimentation in Teaching Biology
- Unit 3 Modern Techniques of Teaching Biology I
- Unit 4 Modern Techniques of Teaching Biology II

Module 2 Resources and Planning for Biology Teaching

- Unit 1 Resources for Teaching Biology: Teaching Materials/aids and Community Resources
- Unit 2 Textbooks in Teaching Biology: Selection and Use
- Unit 3 Improvisation in Biology Teaching
- Unit 4 Teaching Units and Unit Planning
- Unit 5 Lesson Preparation and Lesson Plan

Module 3 Laboratory Design, Management and Safety

- Unit 1 Laboratory Facility: Biology Laboratory Design
- Unit 2 Managing the Biology Laboratory
- Unit 3 Safety in the Biology Laboratory

Module 4 Evaluation in Biology Teaching

- Unit 1 Evaluation of Theory I (Objectives and Essay Questions)
- Unit 2 Evaluation of Theory II (Objectives and Essay Questions: Application, Analysis, Synthesis and Evaluation)
- Unit 3 Other Teacher-Made Evaluation Procedures

Each study unit consists of three to six weeks work and includes specific objectives, directions for study, reading materials and summaries of key ideas and issues. Each unit contains a number of self-assessment exercises. In general, the self-assessment exercises questions you on the material you have just covered or require you to apply it in some way and thereby, help you gauge your progress and to reinforce your understanding of the material.

Textbooks and References

Every unit contains a list of references for further reading. Try to get as many as possible of those textbooks and materials listed. The textbooks and materials are meant to deepen your knowledge of the course. You must endeavor to have one or two of the under listed books.

Federal Ministry of Education (2013). *Biology Curriculum for Senior Secondary Schools*. NERDC Press.

Dienye, N.E. & Gbamanja, S.P.T. (2017). *Science Education: Theory and Practice*. Ibadan: Totan Publishers.

Maduabum, M.A. (2016). *Learning integrated science effectively*. Onitsha: Space matrix Publications. Article.

Maduabum, M.A. (2013). *Teaching Integrated Science Effectively*. Onitsha: Space Matrix Publishers.

Uche, S.C. & Umoren, G.U (2019). *Integrated Science Teaching: Perspectives and Approaches*.

Assessments

There are three aspects of the assessment. First are the Self-Assessment Exercises (SAEs) second is the Tutor-Marked assignments (TMA) and the third is the Final Examination.

At the end of the course, you will need to sit for a final written examination of two hours duration. This examination will also account for 70% of your total course mark.

Self-Assessment Exercises

Here you are expected to apply knowledge, information and skills that you have acquired during the course. Self-assessment exercises are interspersed throughout the units to help you understand each unit you have studied. Working through these exercises will help you to achieve the objectives of the unit and prepare you for the assignments and the examination. Make sure that you note and if possible do all the activities suggested within the study units.

Tutor-Marked Assignment

In addition to the fifteen units assignments at the end of each unit you are going to take three Tutor-Marked Assignments (TMA) on this course. You are advised to attempt all the TMAs. The TMAs may be a Fill-in –the –Blank space (FBQ) or Multiple Choice Questions (MCQ) format. Each of the TMAs carries 10Marks. Therefore the total score for the three TMAs is 30Marks.

Final Examination and Grading

The final examination for this course - EDU 750 will be for three hours duration, and will constitute 70% of your final grade. The examination, which shall last for three hours, will consist of questions, which reflect the types of self- testing, practice exercises and other tutor-marked assignments you have previously encountered. All areas of the course will be assessed.

You are advised to use the time between finishing the last unit and sitting for the examination to revise the entire course. You might find it useful to review your self-assessment exercises, tutor-marked assignments and comments on them before the examination.

Course Marking Scheme

The work you submit will count for 30% of your total course mark. At the end of the course you will be required to sit for a final examination which will also count for 70% of your total marks . The grand total score for the course is 100%.

Course Overview

This section brings together the units and the number of weeks you should take to complete them.

Course Guide

Unit	Title of Work	Weeks
Module 1 Methods and Techniques of Teaching Biology 1		
Unit 1	Traditional Methods of Teaching Biology	4Weeks
Unit 2	Demonstration and Experimentation in Teaching Biology	3Weeks
Unit 3	Modern Techniques of Teaching Biology I	3Weeks
Unit 4	Modern Techniques of Teaching Biology II	3Weeks
Module 2 Resources and Planning for Biology Teaching		
Unit 1	Resources for Teaching Biology: Teaching Materials and Aids and Community Resources	4Weeks
Unit 2	Textbooks in Teaching Biology: Selection and Use	3Weeks
Unit 3	Improvisation in Biology Teaching	4Weeks
Unit 4	Teaching Units and Unit Planning	3Weeks
Unit 5	Lesson Preparation and Lesson Plan	4Weeks
Module 3 Laboratory Design, Management and Safety		
Unit 1	Laboratory Facility: Biology Laboratory Design	3Weeks
Unit 2	Managing the Biology Laboratory	3Weeks
Unit 3	Safety in the Biology Laboratory	3Weeks

Module 4 Evaluation in Biology Teaching		
Unit 1	Evaluation of Theory I (Objectives and Essay Questions)	3Weeks
Unit 2	Evaluation of Theory II (Objectives and Essay Questions: Application, Analysis, Synthesis and Evaluation)	4Weeks
Unit 3	Other Teacher-Made evaluation Procedures	3Weeks
Revision		2Weeks
Total		54

How to Get the Best from this Course

In distance learning, the study materials are specially developed and designed to replace the lecturer. This is one of the great advantages of distance learning; you can read and work through these materials at your own pace, and at a time and place, that suits you best.

Visualize it as reading the lecture instead of listening to the lecturer. In the same way a lecturer might give you some reading to do. The study units tell you when to read, and which are your text materials or set books. Just as a lecturer might give you an in-class exercise, you are provided with exercises to do at appropriate points. The course materials are interactive enough and allow you to fill the gap created by the absence of the teacher in a face to face encounter. However the online synchronous facilitation and the instructional video supplements are also meant to bridge this gap.

Each of the study units follows a common format. The first item is an introduction to the subject matter of the unit, and how a particular unit is integrated with the other units and the course as a whole. Next is a set of learning outcomes. These learning outcomes let you know what you should be able to do by the time you have completed the unit. You should use these outcomes to guide your study.

When you finish a unit, you must go back and check whether you have achieved the objectives. If you make this a habit, you will significantly enhance your chances of passing the course.

The main body of the unit guides you through the required reading from other sources. This will usually be either from your set books or from a reading section. Some units require you to undertake some practical activities. You may be asked to write a lesson plan, to improvise some teaching material or any such activity. Ensure that you do whatever you are asked to do because it will increase your chances of understanding the course better, and doing well in the examination. Self-assessment exercises are interspersed throughout the units. They are to guide you in

ensuring that you understand each unit you have studied. Working through these exercises will help you to achieve the objectives of the unit and prepare you for the assignments and the examination. Make sure that you note and if possible do all the activities suggested within the study units.

The following is a practical strategy for working through the course. If you run into any trouble, telephone your tutor or visit the Study Centre nearest to you at the designated time that has been communicated to you. Remember that your tutor's job is to help you. When you need assistance, do not hesitate to call and ask your tutor to provide it.

1. Read this *Course Guide* thoroughly.
2. Organize a study schedule. Refer to the Course Overview for more details. Note the time you are expected to spend on each unit. Important information, e.g. details of your tutorials, and the date of the first day of the Semester is available from the study centre. You need to gather all the information into one place, such as your diary or a wall calendar. Whatever method you choose to use, you should decide on and write in your own dates, and schedule for working on each unit.
3. Once you have created your own study schedule, do everything you can to stick to it. The major reason that students fail is that they get behind with their course work. If you get into difficulties with your schedule, please, let your tutor know before it is too late for help.
4. Turn to Unit 1, and read the introduction and the objectives for the unit.
5. Assemble the study materials. You will always need both the study unit you are working on and your set books on your desk any time you are studying.
6. Work through the unit. The content of the unit has been arranged to provide sequence for you to follow. As you work through the unit, you will be instructed to read sections from your set books or other sources for further information.
7. Keep in touch with your study centre. This will enable you have any new information that you need.
8. Well before the relevant due dates (about 4 weeks before due dates); visit the study centre to find out if there is new information about the assignments. Keep in mind that you will learn a lot by doing the assignments carefully. They have been designed to help you meet the objectives of the course and, therefore, will help you pass the examination. Submit all assignments no later than the due date.
9. Review the objectives for each study unit to confirm that you have achieved them. If you feel unsure about any of the objectives, review the study materials or consult your tutor.

10. When you are confident that you have achieved a unit's objectives, you can start on the next unit. Proceed unit by unit through the course and try to pace your study so that you keep yourself on schedule.
11. When you have submitted an assignment to your tutor for marking, do not wait for its return before starting on the next unit. Keep to your schedule. When the Assignment is returned, pay particular attention to your tutor's comments, both on the tutor- marked assignment form and the written comments on the assignments. Consult your tutor as soon as possible if you have any questions or problems.
12. After completing the last unit, review the course and prepare yourself for the final examination. Check that you have achieved the unit objectives (listed at the beginning of each unit) and the course objectives (listed in the Course Guide).

Facilitators/Tutors and Tutorials

The dates, times and locations of these tutorials will be made available to you, together with the name, telephone number and the address of your tutor. Your tutor will mark and comment on each assignment, keep a close watch on your progress and on any difficulties you might encounter and assist you during the course.

Pay close attention to the comments your tutor might make on your assignments as these will help in your progress. Make sure that assignments reach your tutor on or before the due date.

Do not hesitate to contact your tutor if you need help. You should contact your tutor if:

- You do not understand any part of the study units or the assigned reading.
- You have difficulty with the self-tests or exercises
- You have a question or problem with an assignment, with your tutor's comments on an assignment or with the grading of an assignment.

Your tutorials are important; therefore do not skip any. This is the only opportunity to meet your tutor face- to- face. It also enables you to meet other students on the same programme. It is an, opportunity to get the help of your tutor and discuss any difficulties you encounter as you study. To gain the maximum benefit from course tutorials, prepare a question list before attending them. You will learn a lot if you participate actively in discussions.

Summary

This course, EDU 750 intends to:

1. introduce you to the basic methods and techniques of teaching biology,
2. familiarize you with the resources for teaching biology,
3. expose you to the need for proper planning before embarking on teaching any topic in biology,
4. explain to you how to make appropriate use of the laboratory in teaching biology, and
5. teach you the various tools and techniques for assessing learning outcomes in biology.

When you complete the course, you will be equipped to teach biology effectively in the secondary school.

We wish you success with the course and pray that you will find it both useful and interesting.

**MAIN
COURSE**

CONTENTS

Module 1	Methods and Techniques of Teaching Biology	1
Unit 1	Traditional Methods of Teaching Biology.....	1
Unit 2	Demonstration and Experimentation in Teaching Biology	12
Unit 3	Modern Techniques of Teaching Biology I	21
Unit 4	Modern Techniques of Teaching Biology II.....	33
Module 2	Resources and Planning for Biology Teaching	42
Unit 1	Resources for Teaching Biology: Teaching Materials/aids and Community Resources.....	42
Unit 2	Textbooks in Teaching Biology: Selection and Use	51
Unit 3	Improvisation in Biology Teaching.....	59
Unit 4	Teaching Units and Unit Planning.....	66
Unit 5	Lesson Preparation and Lesson Plan.....	77
Module 3	Laboratory Design, Management and Safety	85
Unit 1	Laboratory Facility: Biology Laboratory Design	85
Unit 2	Managing the Biology Laboratory.....	91
Unit 3	Safety in the Biology Laboratory	99
Module 4	Evaluation in Biology Teaching.....	107
Unit 1	Evaluation of Theory I (Objectives and Essay Questions)	107
Unit 2	Evaluation of Theory II (Objectives and Essay Questions: Application, Analysis, Synthesis and Evaluation)	115
Unit 3	Other Teacher-Made Evaluation Procedures.....	123

MODULE1 METHODS AND TECHNIQUES OF TEACHING BIOLOGY 1

Unit 1	Traditional Methods of Teaching Biology
Unit 2	Demonstration and Experimentation in Teaching Biology
Unit 3	Modern Techniques of Teaching Biology I
Unit 4	Modern Techniques of Teaching Biology II

UNIT 1 TRADITIONAL METHODS OF TEACHING BIOLOGY

Unit Structure

- 1.1 Introduction
- 1.2 Learning Outcomes
- 1.3 Lecture Method in Biology Teaching
 - 1.3.1 Advantages of Lecture Method
 - 1.3.2 Disadvantages of Lecture Method
 - 1.3.3 Suggestions for the Use of Lecture Method
- 1.4 Discussion Method in Biology Teaching
 - 1.4.1 Advantages of Discussion Method
 - 1.4.2 Disadvantages of Discussion Method
 - 1.4.3 Suggestions for the Effective Use of Discussion
- 1.5 Project Method in Biology Teaching
 - 1.5.1 Advantages of Project Method
 - 1.5.2 Disadvantages of Project Method
 - 1.5.3 Suggestions for the Effective Use of Project Method
- 1.6 Field Trip in Biology Teaching
 - 1.6.1 Advantages of Field Trip
 - 1.6.2 Disadvantages of Field Trip
 - 1.6.3 Suggestion for the Effective Use of Field Trip
- 1.7 Summary
- 1.8 References/Further Reading/Web Resources
- 1.9 Possible Answers to Self-Assessment Exercises



1.1 Introduction

The teaching of biology requires that the teacher should be knowledgeable in the various methods and strategies for teaching the subject. The application of particular method will help the biology teacher to achieve the desired learning outcomes. This unit therefore examines the traditional methods of teaching biology. Specifically, the unit examined the lecture method, discussion method, and project method as well as field trip and excursion. The advantages,

disadvantages and suggestions for the effective use of such methods, were highlighted.



1.2 Learning Outcomes

By the end of this unit, you should be able to:

- Explain the lecture method
- List the advantages and disadvantages of lecture method
- Suggest ways of making the use of lecture method more effective
- Explain discussion method
- List the advantages and disadvantages of discussion method
- Suggest ways of making use of discussion method more effective
- explain the term field trip and excursions
- List some advantages and disadvantages of field trip and excursion
- Suggest ways of making use of field trip more effective.



1.3 Lecture Method in Biology Teaching

The use of lecture method entails a one way flow of communication from the teacher to the students. It is a teacher-centred or teacher-dominated approach. Most of the talking is carried out by the teacher while the students remain as passive listeners taking down notes. Hence it is referred to as didactic approach or talk-chalk.

Most teaching carried out in our schools today are through the use of lecture method. This is because large amount of information can be presented to students in a limited time. Most teachers embrace the use of this method due to the fact that it leads to coverage of the syllabus.

It can be used to teach large and small class sizes. The teacher may ask few or no questions in the process. It does not require the use of instructional materials or resources. To this effect, the students are denied the opportunity of developing manipulative skills. The lecture method is only concerned with verbal presentation of concepts and ideas to the students. Hence, it does not promote meaningful learning since students are not actively involved in the learning process. The longer the teacher talks to a group of students, the less the students retain the information presented to them.

1.3.1 Advantages of Lecture Method

1. Less time is required on the part of the teacher in preparing for his lessons since no materials are needed in the process.
2. It is cheap to operate.
3. It is a good method for delivering large amount of knowledge in a short time. i.e. it leads to a very high content coverage.
4. It can be used to handle large classes.
5. It can be used to introduce new topics.
6. It helps to channel the students thinking towards a particular direction.
7. It helps the teacher to develop confidence in his teaching as a facilitator of knowledge.

1.3.2 Disadvantages of Lecture Method

1. Students are passive listeners and do not participate actively as the lesson progresses.
2. Lecture method does not put into consideration the individual differences of the learners.
This is because a class is made up of students with a wide range of intellectual abilities- high, medium and low.
3. The non- active participation of students does not provide the teacher with the opportunity to evaluate the students during the lesson period.
4. With lecture method, the students do not practice communication skills.
5. Lecture method is not very good for teaching certain concepts in biology that may require attitude and feelings of students.
6. Lecture method encourages memorization of information (rote learning) without actually promoting meaningful understanding.
7. It does not promote meaningful learning of biology concepts.

1.3.3 Suggestions for the Use of Lecture Method

1. Lecture method should be used in junction with other methods of teaching. This will help to enhance students' participation in the lesson.
2. As much as possible, avoid coverage of too many topics, which may lead to boredom and tend to confuse the students.
3. Encourage active participation of students in class through asking questions and giving them opportunity to make comments.
4. At the end of each lesson period, the teacher should summarize the key points

Self-Assessment Exercise 1

1. The lecture method can be made more effective by all of these except
 - A. Avoid coverage of too many topics.
 - B. Summarize the main points after the lesson
 - C. Providing students with textbooks.
 - D. Asking Students questions as the lesson progresses
2. State three advantages of the lecture method in teaching biology.

1.4 Discussion Method in Biology Teaching

Discussion can be seen as talking over something from various points of view. Discussion usually involves a group of people. Under a classroom setting, discussion is an interactive process involving the teacher and the students or among the students themselves. In this case, a problem or topic for the lesson is presented for discussion while the teacher helps to direct their views towards the lesson objectives.

Discussion is different from lecture method. While the lecture method is a one way flow of communication between the teacher and the students, discussion involves a multiple flow of communication arising from the members of the group. Discussion method encourages students' active involvement in the learning. Students generate a variety of ideas, which will lead to the solution of the problem while the teacher acts as a moderator in the learning process.

For a successful implementation of discussion method, every student should have background knowledge of what is to be discussed otherwise it becomes a waste of time which may lead to lack of interest in the subject. In other words, using discussion method to teach a topic the students have no knowledge about will be counterproductive. Discussion method tends to promote meaningful learning of science concepts.

1.4.1 Advantages of Discussion Method

1. Discussion method encourages students learning through active participation in the classroom.
2. It enables the teacher to have better knowledge of his students' abilities and attitudes.
3. There is greater interpersonal relationship between the teacher and students and among students themselves.
4. Discussion can lead to the development of leadership qualities.
5. Discussion aids in problem solving.

1.4.2 Disadvantages of Discussion Method

1. Discussion method takes a considerable length of time. This is due to the fact that each student will be given opportunity to contribute to the discussion.
2. In some cases, students may find it extremely difficult to contribute meaningfully to the discussion. This is as a result of poor background knowledge of the topic to be discussed.
3. In terms of content coverage, discussion method does not lend itself to easy coverage of the syllabus.
4. Some student who lacks background knowledge of most of the topics discussed may begin to be disinterested in the subject.
5. Lack of student's participation in the discussion may reduce their understanding of the lesson.

1.4.3 Suggestions for the Effective Use of Discussion

1. Topics for the discussion should centre on those in which students have requisite background knowledge.
2. Let the students know about the topic to be discussed some days prior to the discussion class. This will help them to read up and be able to contribute meaningfully in the discussion.
3. The teacher should try to avoid a situation whereby a student or few students dominate the discussion.
4. The teacher should encourage student's efforts by giving positive reinforcement in the form of praise for good intellectual contributions while also rejecting the irrelevant comments and questions.
5. In order to elicit more students' responses, the teacher can ask those questions for more information.
6. The teacher should not allow the students to completely deviate from the objectives of the discussion but rather intervene in such cases.
7. The teacher should clarify students on areas that may seem difficult for meaningful discussion.
8. Use all the meaningful contributions to form the blackboard summary.
9. The teacher may give students assignments on the topic to enhance their learning potentials.

Self-Assessment Exercise 2

- | |
|--|
| <ol style="list-style-type: none">1. State two disadvantages of the discussion method2. List two ways the discussion method can be made more effective. |
|--|

1.5 Project Method in Biology Teaching

Projects are organized or planned activities in which students are allowed to investigate or research on their own. Project method can be used to individualize instruction or it can be used on a group of students. For example five students, ten students or a whole class can be asked to execute a project. Projects usually are given for a period of time for instance 3days, one week or even months. They may be carried out during or outside class work.

Teachers may assign project topics to the students while in some cases; students are allowed to choose any topic that might be consistent to their interest. Project method provides opportunities for greater understanding among students. It requires a bit of originality and creativity. It can be used by teachers to solve the problem of individual differences among students.

Some examples of project topics in biology include:

- (1) Reading of Scientific Journals.
- (2) Planting of Seeds.
- (3) Drawing any of the body systems.

1.5.1 Advantages of Project Method

1. Project method helps to solve the problem of individual differences since each student can carry out their own work at his/her own pace.
2. The emphasis on project is “doing” so students are given the opportunity to develop their initiative.
3. Motivation to work is usually very high since it is based on student’s interest particularly for students with special talents.
4. Group projects afford opportunities for developing leadership qualities.
5. Project helps students to have an in-depth study of the topic under investigation.

1.5 .2 Disadvantages of Project Method

1. Project method is time consuming since it will surely be more than a day.
2. Project methods are mostly beneficial to students who have the potentials of independent work.
3. It is also very difficult to ascertain the extent to which a particular student has gone with the work since they may invite other people to do the work for them.
4. It is difficult to get a topic that will interest all the students.

1.5.3 Suggestions for the Effective Use of Project Method

1. Provide students with the entire necessary guide that will help them carry out the project effectively.
2. Spread the project over a long period of time to enable them has an in-depth study of the topic.
3. Ensure that the purpose of the project fits properly into the instructional sequence.
4. Ensure that there is objectivity in marking and scoring of the project by developing a marking procedure

Self –Assessment Exercise 3

- | |
|---|
| <ol style="list-style-type: none">1. State three advantages of the project method in teaching biology.2. Suggest three concrete ways of improving on the use of the project method |
|---|

1.6 Field Trip in Biology Teaching

Field trip is one of the methods of teaching biology, which involves taking students outside the classroom setting to have firsthand experiences of what happens in our environment or real life situations. The method enables the students to make useful observations and collect information, which cannot be obtained within the classroom. Experiences acquired during field trip are usually long lasting and cannot easily be forgotten by the students. Examples of areas where students can undertake field trip include erosion sites, industries, oil spillage sites, mountains or hills, rivers, hospitals etc. A study of these phenomena will be more meaningful when students visit the affected sites than when discussed under the classroom setting.

Field trip is highly rewarding if it is well planned and executed. It affords the students the opportunity of observing, collecting, classifying and having an in-depth study of certain concepts and phenomena. With field trips, students get to know their communities and surroundings better. Because it is an enjoyable and exciting experiences, motivation of students to read up what was observed during field trip is usually very high and it helps to generate and sustain students interest towards the subject.

1.6.1 Advantages of Field Trip

1. Field trip provides the students with the opportunity of having first hand knowledge of certain phenomena that occur in our environment.

2. It helps to generate and sustain students' interest in the subject.
3. With field trip, motivation to work is usually very high.
4. It aids retention of information since the experiences are long lasting.
5. Field trip can help students to develop interest in certain professions e.g. engineering, medicine etc.
6. It helps to channel student's experiences towards one direction.
7. Field trip helps students to understand man's relationship with his environment

1.6.2 Disadvantages of Field Trip

1. If it is not well planned, it becomes a waste of time and resources.
1. It is extremely tedious to carry out field trip especially when it involves long distance trip.
2. In some situations, accident may occur in the course of a field trip.
3. In most cases, field trip time encroaches into other lesson periods.
4. This would likely result in conflict between the teachers involved if it is not properly handled.
5. Field trip results in extra financial expenditure on the part of the school and students.

1.6.3 Suggestion for the Effective Use of Field Trip

1. The biology teacher should first discuss the idea of taking students on a field trip with the school authority for approval.
2. Subsequently, she should write to the managing director (MD) if it involves an industry for permission to visit, time of the visit as well as the date of the visit. Finally request for any written rules guiding the place.
3. Before the trip the biology teacher should then discuss with the students concerning the trip, the aim of the visit, materials to take along ego pen, pencil, exercise book, ruler etc.
4. Furthermore, the teacher should inform the students about the rules guiding the place, possible dangers, things to look out for as well as method of reporting their observations.
5. The teacher should make sure that the field experience fits properly into the instructional sequence.
6. The biology teacher should carry first aid kit along in case of any accidents involving students.
7. Ensure adequate arrangement for transportation in the case of trips involving long distances.
8. After the trip, examine the students on the specimens and information collected from the trip. This has to be in connection

with the report of the trip in order to facilitate retention of the experiences from the trip.

Self-Assessment Exercise 4

1. Explain what you understand by field trip in biology teaching.
2. State any 2 advantages and 2 disadvantages of the use of field trip



1.7 Summary

In this unit we have learnt traditional methods of teaching biology e.g. lecture method, discussion, project and field trip

- The lecture method is a one way flow of communication from the teacher to the student.
- There are seven advantages and seven disadvantages identified on the use of lecture method.
- Four suggestions were made that will guide the biology teacher on the effective use of lecture method.
- The discussion method is an interactive process involving the teacher and the students themselves.
- There are five advantages and five disadvantages on the use of discussion method.
- Nine suggestions were made on the use of discussion method. The project method is an organized and planned activity in which students are allowed to investigate or research on their own.
- There are five advantages and four disadvantages on the used project method.
- Four suggestions were made on the use of project method.
- The field trip is one of the methods of teaching in which students are taken out of the classroom setting to have 'firsthand experience of what happens' in our natural environment or real life situations.
- There are seven advantages and five disadvantages on the use of trip in biology teaching.
- Eight suggestions were made on the effective use of field trip.



1.8. References /Further Reading/Web Sources

Maduabum, M.A (2013). *Teaching Integrated Science effectively*. Onitsha Space Matrix Publications.

Nnaka, C.V. (2011) *Teaching the Concept of Living and Non – Living Things*: In STAN Biology Panel Series, 2011.J. Okoli and U.M.Nzewi (Eds.)

Dienye, N. E & Gbamanja, S.P.T (2017). *Science Education. Theory & Practice*. Ibadan. Totan Publishers Ltd.

Abdullahi, A. (2016). *Science Teaching in Nigeria*. Ilorin. Atoto Press Limited.

Taylor and Francis (2003) *Learning and Teaching Programming: A Review and Discussion*. Volume 13 Issue 2, 2003.

Visit www.studyquirk.com

Emmadiole, N.B. & Okafor, C.U. (2014) *Strategies Teachers can use to inspire Creativity in Senior Secondary School Biology Students*. Science Teachers Association of Nigeria, 55th Annual Conference Proceedings . Published by STAN, 2014, p.200



1.9 Possible Answers to Self –Assessment Exercises

SAE 1

1. Answer is C. - Provide students with textbooks
2. Three advantages of lecture method –
3. A large portion of the syllabus can be covered.
4. It is cheap to operate
5. Teacher requires less time to prepare the lesson.

SAE 2

- 1 Discussion method consumes a lot of time.
- 2 Some students may find it difficult to contribute to the lesson due to poor background information on the topic.
- 3 Discussion method can be made more effective by
 - a. Giving students advance information about the topic to be discussed
 - b. Summarizing all the meaningful contributions on the blackboard.

SAE 3

1. Project method gives students opportunity to develop leadership qualities.
2. Helps students to get in depth study of the topic.
3. Helps to solve the problem of individual differences.

SAE 4

1. Field trip is a teaching method in which the students are taken out of the classroom into the environment to see the real specimens and also the real life situation.

Advantages

1. It helps the students to understand man's relationship with the environment.
2. It motivates the students.

Disadvantages --

1. It is expensive
2. Accidents may occur .

UNIT 2 DEMONSTRATION AND EXPERIMENTATION IN TEACHING BIOLOGY

Unit Structure

- 2.1 Introduction
- 2.2 Learning Outcomes
- 2.3 Demonstration in Biology Teaching
 - 2.3.1 Advantages of Demonstration
 - 2.3.2 Disadvantages of Demonstration
 - 2.3.3 Suggestions for the Effective Use of Demonstration
- 2.4 Experimentation in Biology Teaching
 - 2.4.1 Advantages of Experimentation
 - 2.4.2 Disadvantages of Experimentation
 - 2.4.3 Suggestions for the Effective Use of Experimentation
- 2.5 Summary
- 2.6 References/Further Readings/Web Sources
- 2.7 Possible Answers to Self-Assessment Exercises



2.1 Introduction

In the preceding unit, we discussed the traditional methods of teaching biology. Demonstration and Experimentation are other methods of biology teaching. Biology being a science subject requires a lot of demonstration and experimentation on the part of the teacher. This is due to the fact that the subject involves a lot of students and the practical works which the biology teachers have to carry out. Both demonstration and experimentation require equipment and materials for creating relevant activities. Hence they are activity-oriented learning.



2.2 Learning Outcomes

By the end of this unit, you should be able to:

- explain the use of demonstration in biology teaching
- state the advantages and disadvantages of demonstration
- mention specific principles for the effective use of demonstration
- explain experimentation in biology teaching
- state the advantages and disadvantages of experimentation
- enumerate some specific principles that should guide the use of experimentation.



2.3 Demonstration in Biology Teaching

Demonstration in biology teaching simply entails a display or an exhibition usually carried out by the teacher while the students watch. It is mostly used in showing the students correct use of certain science equipment. Demonstration can be carried out by a single teacher alone or by a student or group of students.

Certain activities in biology that may require demonstration include: action of iodine on green leaf, dissection of animal, manipulation of equipment like microscope, action of iodine on cooked starch. In all these activities, demonstration can be used to illustrate the phenomena to the students. Most of the activities carried out in our schools today by teachers are through demonstration lessons.

Demonstration can be used to carry out expensive or difficult experiments, which may expose students to danger. Ability to observe clearly is very important in demonstration.

2.3.1 Advantages of Demonstration

1. Demonstration is an inexpensive method of teaching biology since only the demonstrator needs materials.
2. Secondly damages and breakages of science equipment are likely not to occur due to the expertise of the teacher.
3. Demonstration helps to reduce hazards in the laboratory e.g the chances of accidents occurring among students.
4. With demonstration, activities which may be risky or expensive for students can be carried out effectively.
5. Demonstration can be used to introduce a new lesson to the students. In other words, it can be regarded as attention inducer because the students will be eager to see and know what the demonstrator is trying to do.
6. The proficiency displayed by the demonstrator reduces the error or time in carrying out the experiment
7. A good demonstration facilitates learning by making the learners to be alert and attentive as the lesson progresses.
8. Demonstration can be used to review experiments which the students have carried out previously e.g. practical carried out by students in SS 1 and SS2 can be revised in SS3 through the use of demonstration activity.

2.3.2 Disadvantages of Demonstration

With demonstration, less scope is covered. Since it takes time for students to get familiar with the procedure, equipment or materials used for the exercise

1. In a situation where the class size is very large e.g. up to fifty students; visibility of details of what the teacher is doing is not assured. This is particularly so in cases where small sized equipment or objects are used
2. In a situation where students are not completely involved in carrying out the demonstration, those involved in the learning process may be restricted to a few of them
Furthermore, in cases where the demonstration is restricted to the teacher alone, students find it extremely difficult to acquire manipulative skills
3. Demonstration is also time consuming and does not lead to coverage of the syllabus
4. With demonstration, ability of the students to observe correctly is an important parameter in achieving success in the learning process.

2.3.3 Suggestions for the Effective Use of Demonstration

1. Before the lesson commences, the teacher should assemble in advance all the necessary materials and equipment to be used for the demonstration lesson.
2. The biology teacher should try out the demonstration first to ensure his competence and the workability of the equipment before carrying it out with the students.
3. Students sitting arrangement should be such that smaller ones in front and tall ones behind. This arrangement will enable all the students to observe the demonstration clearly.
4. The teacher's voice is also very important in demonstration; hence he needs to be audible especially in large classes.
5. Few students could be called upon to repeat the demonstration if time permits.
6. At the end of the demonstration, the key points or the procedure should be written on the board for students in form of blackboard summary.

Self-Assessment Exercise 1

- | |
|--|
| <ol style="list-style-type: none">1. What is demonstration?2. State any two disadvantages of demonstration method |
|--|

2.4 Experimentation in Biology Teaching

Experimentation is a method of learning science concepts not through what the teacher told the students, but through what involve in the process of investigation, carrying out experiments as well as other practical activities. Experimentation involves activity-oriented learning. In this case, the emphasis is on doing. Most times, the activities are carried out in the biology laboratory. A laboratory is a room or building set aside for scientific investigations.

Experimentation is a means of acquiring science process skills such as observation, measuring, classifying objects or things, defining variable operationally, designing experiments, interpreting data, hypothesizing, predicting etc. Experiments in biology can be carried out by individual students or group of students working together. The latter is used when the equipment and materials needed for the experimentation cannot go round to individual students.

Experimentation is a means by which students acquire meaningful learning of science concepts to the point of achieving transfer and application of knowledge. Hence it exposes them to acquire attitudes and skills of a scientist. This method of teaching science has proved to be one of the most effective ways of learning.

The laboratory work involved in the process of experimentation can be broken down into different phases since it involves whole class activity.
Phase One -Pre-laboratory Session
Phase Two -Laboratory Session
Phase Three -Post laboratory session

Phase One–Pre–Laboratory Session

For a biology teacher to carry out effective experimentation in biology laboratory, careful planning and proper organization are necessary. To this effect, he needs to assemble in advance all the equipment and materials for the exercise. Furthermore, he has to ensure that they are also in good working condition. Subsequently, the experiment is trial tested by carrying it out first to ensure that the chemicals to be used are still very active and the procedure carefully followed by the teacher. This pre-laboratory session is very important because it reduces errors which the teacher may have committed in the actual laboratory session. Also the sitting arrangements of students are put into consideration as well as the time to spend in carrying out the investigation.

Phase Two–Laboratory Session

During the laboratory session, the teacher will first of all interact with the students by telling them what to do, the purpose of the experiment, the procedure to be followed in carrying out the investigation as well as

safety measures to be taken to avoid incidence of accident. Thereafter, while students are now working with their equipment and materials, the teacher's duty is to be an overseer. He works round the class to make sure that all the students are following the procedure carefully. The teacher clarifies any doubt or problem arising from the students and by so doing gives them adequate encouragement and support in the learning process.

Phase Three–Post Laboratory Session

In this session, the teacher discusses the result of the investigation in order to clarify students who may be in doubt. He can assign marks to the work done by the students. The teacher can also summarize the process as well as the result of the investigation in the form of blackboard summary. Finally students are allowed to clean up their tables and wash off equipment before leaving the laboratory. This is very important especially in cases where there is no laboratory assistant.

2.4.1 Advantages of Experimentation

1. Experimentation enables students to have direct sensory experience of scientific knowledge e.g. working with living organisms; it enables the learner not only to acquire knowledge but also to appreciate life.
2. Experimentation fosters opportunities for the acquisition of science process skills e.g. manipulation, measuring, classifying etc.
3. It helps in the retention of information as the students interact with the scientific process.
4. The uses of experiments help students to develop scientific attitude such as enquiry, curiosity, carefulness, objectivity, honesty etc.
5. Experimental works help to stimulate and sustain student's interest in science.
6. It aids students in problem solving and arriving at conclusions.
7. It helps to increase student's ability towards critical thinking and acquisition of better understanding of scientific knowledge

2.4.2 Disadvantages of Experimentation

1. Experimentation in biology teaching is wasteful in terms of resources to be used in carrying out the investigation unlike demonstration.
2. It is also time consuming in carrying out a single experiment. What the teacher can say in five minutes may take one hour to investigate.
3. It also exposes the teacher's ignorance on those areas he is not competent enough to handle.

4. In experimentation, lack of background knowledge about the activities may make students to dislike the subject

2.4.3 Suggestions for the Effective Use of Experimentation

1. Experiments should be based on students' background and availability of materials.
2. The teacher should ensure that the time frame for the experimentation will be such that students will be able to achieve results at the end of the time.
3. The language of instruction for any investigation should be very clear and within the child's chronological age.
4. The teacher should make sure that the equipment for students are in good working condition and enough materials are available for all the students.

Self-Assessment Exercise 2

- | |
|--|
| <ol style="list-style-type: none">1. State 2 advantages of experimental method.2. Suggest 2 guidelines on the effective use of experimentation in teaching biology. |
|--|



2.5 Summary

In this unit, we have learnt that:

1. Demonstration simply means a display or an exhibition usually carried out by the teacher while the students watch.
2. Demonstration can be used to carry out expensive or difficult experiments which may expose students to danger.
3. There are some advantages and disadvantages of using demonstration in teaching.
4. There are also some suggestions that may guide a biology teacher on how to use demonstration as a teaching strategy.
5. Experimentation is a method of learning science through the process of investigation as well as carrying out practical activities.
6. Experimentation is an activity-oriented teaching method.
7. The laboratory exercise could be broken down into three different phases-pre-laboratory, laboratory and post-laboratory
8. There are some advantages and disadvantages of experimentation.
9. There are some suggestions that guide a biology teacher in the process of carrying out experiments.



2.6 References/Further Readings/Web Sources

- Ezeife. A. M. (2017). *Physics Methods: The Methodology of Physics Teaching*. Nsukka: Enugu University Trust Publishers.
- Maduabum. M. A. (2019). *Teaching Integrated Science Effectively*. Onitsha Space Matrix Publication.
- Abdullahi. A. (2011). *Science Teaching in Nigeria* Ilorin. Atoto Press Limited.
- Thomas M.D., David H. Jonassen (2012) *Designing Environments for Constructive Learning*. Springer Publishing Company.
- Greiff. S. Molnar, Andreas, Funke (2013). *Rethinking University Teaching: A conventional Framework for the Effective use of Learning Technologies*, Oxon; Routledge Falmer Publisher.



2.7 Possible Answers to Self-Assessment Exercise

SAE 1

1. Demonstration is a display carried out in the classroom or laboratory by the teacher or group of students to show the correct use of certain science equipment
2. Disadvantages-1.Students cannot acquire manipulative skills
2. It is time consuming and does not lead to coverage of the syllabus.

UNIT 3 MODERN TECHNIQUES OF TEACHING BIOLOGY 1

Unit Structure

- 3.1 Introduction
- 3.2 Learning Outcomes
- 3.3 Concept Mapping
 - 3.1.1 Advantages of Concept Mapping
 - 3.1.2 Disadvantages of Concept Mapping
 - 3.1.3 Suggestions for the Effective Use of Concept Mapping
- 3.4 Constructivism in Biology Teaching
 - 3.4.1 Advantages of Constructivism as a Teaching Strategy
 - 3.4.2 Disadvantages of Constructivism
- 3.5 Focus Group Discussion
 - 3.5.1 Advantages of Focus Group Discussion
 - 3.5.2 Disadvantages of Focus Group Discussion
 - 3.5.3 Guidelines for the Effective Use of Focus Group Discussion
- 3.6 Use of Analogy in Biology Teaching
 - 3.6.1 Advantages on Use of Analogy
 - 3.6.2 Disadvantages of Use of Analogy
- 3.7 Summary
- 3.8 References/Further Readings/Web Sources
- 3.9 Possible Answers to Self-Assessment Exercises



3.1 Introduction

The traditional methods of teaching biology, which was examined in unit 1 emphasized on rote learning and memorization of concepts without actually exposing students to challenges that will make them actively involved in the learning process. The over reliance on these methods in our secondary school science teaching has tended to affect students' performance in the subject. There is need to improve biology teaching and learning through the use of more effective teaching methods. This present unit lays emphasis on those methods that will result to more effective learning of biology. We are therefore going to examine the following modern techniques of biology teaching.

- (1) Concept Mapping
- (2) Constructivism
- (3) Use of Analogy
- (4) Focus Group Discussion



3.2 Learning Outcomes

By the end of this unit, you should be able to:

- Apply concept mapping, constructivism, analogy and focus group discussion in biology teaching
- State their advantages
- List some of their disadvantages
- Discuss some guidelines for the effective use of such methods.



3.3 Concept Mapping

Concept mapping was developed to improve science teaching and learning through more innovative teaching strategies. Concept mapping was developed by Novak and his associates at Cornell University in 1992.

Concept mapping simply means a diagrammatic representation of concepts using arrows to indicate their relationships in order to represent a new knowledge structure.

Concept map may be defined as a schematic device for representing a set of concept meaning embedded in a framework of preposition (Novak and Godwin in Nzewi).

It helps both the teacher and student to pay attention to the major concepts in any given topic, for example, using the topic plant cell. The major concepts may include:

- (1) Cell Wall
- (2) Protoplasm
- (3) Cytoplasm
- (4) Nucleus
- (5) Vacuole

After listing these major concepts/ideas/works they are then arranged in a hierarchy (i.e. a system with different grades from lowest to highest). The most general concepts are placed high up in the hierarchy while the concrete or specific concepts placed below. Then these concepts are connected with lines or arrows showing relationships. A good concept map resembles a road map.

The construction of concept maps can be regarded as a creative activity. The construction is done by the teachers bearing in mind his educational objectives at each point in time. According to Nzewi (2001) for the

construction of concept maps, students should be guided by the following:

1. Note the keywords, phrases or ideas from lessons or text.
2. Arrange them in a hierarchy
3. Draw circles around the concepts
4. Connect the concepts using arrows or lines
5. Provide examples if possible at the end of each branch.
6. Cross-link hierarchies or branches where possible.

3.3.1 Advantages of Concept Mapping

1. Concept mapping helps students to achieve meaningful learning and make teachers to be highly effective in class instruction.
2. It helps them to highlight key concepts in any topic and link them sequentially.
3. Concept mapping helps to represent knowledge in form of a structure or map.
4. Concept mapping helps in understanding of the subject matter better by laying emphasis on the major concepts.
5. Concept mapping makes the students to feel very comfortable and stabilize their emotional state.
6. It has been found to lower student's anxiety in science classrooms.
7. It can be used to teach any subject or any discipline.
8. Concept mapping creates opportunities for students to be highly creative in the learning situation by making new connections and patterns of knowledge structure.
9. Concept maps can be used to suggest further exploration while revealing the extent of knowledge of the individual.

3.3.2 Disadvantages of Concept Mapping

1. In construction of concept mapping, previous knowledge of the individual about the topic affects his representation of the maps.
2. Every map reflects the extent of knowledge of the mapper and the mapper himself.
3. No map is error free. The accuracy of any map depends on the information available to the mapper

3.3.3 Suggestions for the Effective Use of Concept Mapping

1. The class teacher should help students to highlight the key concepts of any topic.
2. Concept mapping should be used along with other strategies otherwise students may loose interest in the learning process.

3. Concept mapping should not be employed for students that are still in their lower classes because its application may be too difficult for them.

SELF-ASSESSMENT EXERCISE 1

1. What is a concept map?
2. State any two advantages of concept mapping in teaching biology
3. Mention one disadvantage of concept mapping.

3.4 Constructivism in Biology Teaching

Constructivism is a kind of learning strategy that lays emphasis on active role of learners in the process of constructing their own knowledge. In other words, science instruction should be child-centered and learning should be an interactive process involving both the teacher and the student. In this case, knowledge is being constructed by the learner in the bid to integrate their experiences into the existing knowledge structure in their memory.

In constructivism, when a learner is faced with a new task, he tries to reformulate his previous knowledge, if the task presented is connected to the existing knowledge in the memory. Through this process, meaningful learning is acquired by the learner. Constructivist theory maintains that learners come into classrooms with ideas concerning the new problem. Therefore learning occurs as a result of interaction between the new information in the learning situation and the experiences gathered as a result of interaction with it. In constructivism, knowledge can be enhanced by instruction but it is not directly applied to instruction. The learner must engage in actively constructing knowledge onto the already existing mental framework for meaningful learning to occur. Hence, the child's individual development is central to instructional process.

The role of the teacher is to organize information around different kinds of problems in order to engage student's interest. In the classroom setting, the students ask questions, carry out experiments and come up with conclusions on their own. Brooks and Brooks (1993) outlined five principles of constructivist learning as follows:

- (1) Posing problems of emerging relevance to students.
- (2) Structuring learning around primary concepts.
- (3) Seeking and valuing student's point of view.
- (4) Adapting curriculum to address student's suppositions.
- (5) Assessing students learning in the context of teaching.

It is therefore very important to note that in constructivism, what the learner already knows is very crucial. This is because in knowledge

construction, the understanding of existing knowledge, interpretation of existing experiences are very important while the teacher guides students to propose alternative framework that will promote knowledge construction.

3.4.1 Advantages of Constructivism as a Teaching Strategy

1. Students are actively involved in the learning process since it is a child centred approach.
2. It considers individual differences among learners. The child's prior ideas as well as their interest and experiences are usually taken into account while planning and executing constructivist lessons.
3. Gives student the opportunity to develop scientific knowledge, ideas and inquiry process.
4. It provides students with opportunities for scientific discussions and debates.
5. Creates a classroom atmosphere that is filled with cooperation, respect and shared responsibility among students.
6. Helps in the learning of subject matter disciplines in the context of interactive process.
7. Helps in assessing students understanding of any topic.
8. Few fundamental science concepts are learned at a time instead of coverage of too many topics as found in lecture method of instruction.

3.4.2 Disadvantages of Constructivism

1. It is time consuming since individual students will be given opportunity to express their ideas.
2. It will not lead to adequate coverage of the syllabus.
3. The use of constructivist approach involves a lot of funds for purchase of materials and equipment.

SELF ASSESSMENT EXERCISE 2

- | |
|---|
| <ol style="list-style-type: none">1. State any three principles of constructivism.2. State two advantages of constructivism. |
|---|



3.5 Focus Group Discussion

Focus group discussion is a tool used for collecting qualitative data or information from members of a group through discussions. Discussion in this case is aimed at eliciting insights and understanding from the group members. The focus group discussion helps in facilitating an organized discussion from members of a group.

In focus group discussion, multiple meanings of certain words or concepts in science can be revealed by different groups. The discussion should be able to evolve new ideas or knowledge. Detailed information about a particular topic in science could be obtained through this method. It is also very important on studies that involve attitude and feelings of students.

The information of the group can be based on different characteristics such as age, gender, race, ability, parental occupation etc. The members of the group should have a common background. In other words, they should be a homogenous group and also be very comfortable.

Usually a group may comprise five to eight students. In the formation of the group, the teacher or moderator should ensure that the group of students for which the topic under discussion is meant for is used in order to elicit correct and proper information.

In focus group discussion, the teacher occupies a key position in the discussion. The teacher directs the discussion without being part of it i.e. a facilitator of knowledge and not to dominate the discussion. A good teacher tries to keep the discussion on its track by asking series of open-ended questions. The teacher's guidance helps to acquire in-depth qualitative information concerning the student's feelings, attitudes, interest and perceptions on the topic discussed. The teacher tries to encourage every student to participate in the discussion instead of allowing a few to dominate the discussion or favoring a particular student.

During the discussion, the teacher may ask probing questions such as: "give us an example of what she is saying", "can you tell us more about that", "okay go ahead and explain" etc.

In a situation, where the students wander away from the objectives of the discussion, the teacher tries to return the conversation to the topic under discussion. The teacher also records every useful comments made by the group as well as individuals.

The role of the teacher not only being highly demanding but also very challenging. The teacher must possess an attribute of a good listener, and nonjudgmental in character. This will help the students to have open interactive dialogue about the topic under discussion.

There are some guidelines that will help the teacher in conducting focus group discussion.

1. At Preparation Level

This involves taking record of all the things that will be used for the discussion, the number of students to be involved, venue for the discussion, developing discussion guide as well as the question to be asked which follow from general questions to specific questions, the amount of time to be used, choice of an appropriate equipment to be used, topic to be discussed which students will understand better, the objectives of the discussion, Benches and tables as well as a closed circuit television may be provided.

2. Members of the Group

This involves selection of the number of students to be involved and the size of each group. The size may range between five to eight students to enable them provide valuable information.

3. At Discussion Level

At this stage, the teacher introduces the topic to be discussed. The teacher moves round each group, standing at the back to watch their discussions. The questions placed on the Discussion table should be in line with the discussion. There may be closed circuit television that records all the activities taking place or the teacher takes notes. The discussion may last between one hour to one and half hours.

4. Moderating the Sessions

This is one of the most difficult tasks since inexperienced teachers may not be able to moderate the session effectively and it becomes a waste of time and resources. It requires having a listening ability to draw information from students.

In the process of moderating the session, the following should guide the teacher.

Keeps the information flowing- The teacher should have firm control of the discussion and not allow a situation where students wander away from the topic of discussion. Every student should be given opportunity to express him or herself.

Period of Discussion -This should depend on the topic at hand as well as the objectives to be achieved.

Teacher Role -The teacher should allow students to do the discussion instead of dominating the discussion.

Post Discussion Session-The teacher talks to all the students. Mentioning the useful points of the discussion and using it to form summary of the lesson.

5. *Analysis of the Discussion*

At this stage, the teacher can review his notes of lesson and highlight key concepts and ideas in greater detail. This can also be accompanied with video tape if available. Ensure that the key points were discussed.

3.5.1 Advantages of Focus Group Discussion

1. Focus group discussion provides insight into what the student knows and those yet to be known.
2. It can be used to ascertain student's needs, experiences and aspirations.
3. Students' views and ideas can be tackled with focus group discussion.
4. Focus group discussion helps to provide an in-depth knowledge of a topic which cannot be obtained from the teacher alone.

3.5.2 Disadvantages of Focus Group Discussion

- (1) The data or information generated may be difficult to analyze since it is not structured.
- (2) Few students who are extroverts may likely dominate the discussion.
- (3) The quality of the discussion depends greatly on the extent of teacher's competence in handling the issues raised in the discussion.
- (4) If the number of students in a group is too small, they may not actually contribute meaningfully in the discussion.
- (5) Although focus group discussion is a powerful strategy in teaching and learning, it may not be used as the only teaching method for students.
- (6) It is time consuming.

3.5.3 Guidelines for the Effective Use of Focus Group Discussion

1. The teacher should bear in mind the level of the students, language level and their chronological age. This will help the teacher in designing the questions for discussion.
2. The general nature of the student~ is also important. Is the group homogenous or heterogeneous in their ability levels?

3. Focus group discussion requires highly experienced teachers in order to guide the discussions properly.
4. The size of the group should not be more than eight students. This enables all the students to participate in the discussion.
5. Create so many groups if the number of students in the class is large.
6. The video, if any, should cover all comments made by the various groups.

Self-Assessment Exercise 3

- | |
|---|
| <ol style="list-style-type: none">1. Explain how you can organize a focus group discussion for your students2. Mention any two advantages of using focus group discussion in teaching biology. |
|---|

3.6 Use of Analogy in Biology Teaching

Analogies are important thinking tools used as a teaching strategy that helps the teacher to relate the old ideas we already know to new ones we are yet to know. It can simply be referred to as similarity i.e. establishment of similarity between certain dissimilar things.

According to Glynn (1991), analogies are comparisons between something that is familiar to students (the base) and an unfamiliar things in science in which teachers want the students to acquire (the target). Furthermore Rigas and Valanides (2003) stated that analogies are representations that people use in order to understand new information or concepts. It involves matching new ideas with the old ones already stored in the memory.

The use of analogy has been found to be very effective in teaching students in that it aids motivation and visualization of difficult concepts in biology. Analogy plays a vital role in scientific explanation of concepts and discovery of new ideas in science.

Science teachers at times use analogy consciously or unconsciously during explanations. Whichever is the case, the teacher should ensure correct application of it to avoid misconceptions that may arise from it. This can be observed when explanations are being made or reacting to students questions especially when such words like “Is the same as”, “what you think is not different from”, “Just like” On the other hand, textbook writers may also use such expression as “in contrast with”, similarly, “in comparison with”, likewise. All these expressions quickly suggest making an analogy with some other thing.

The teacher should guide the students on their use of analogy. The students may list all the things that are related to the concept. It is therefore necessary to sequence analogy so that students will be able to use them at each stage of the lesson. According to Nzewi (2001) there are different forms from which a teacher can draw analogy.

1. Teacher based analogy.
2. Text based analogy.
3. Environmental based analogy.

Secondly, analogy can be drawn from student's cultural background and it is usually more meaningful to them. Familiar analogies are better understood and easily transferred than the abstract ones. Glynn, Law, Gibson & Hewkins (2006) identified six basic operations in teaching with analogy.

- Introduce target concept
- Recall of analogy concept
- Identify relevant features of target and analogy
- Map similarities
- Indicate where analogy breaks down Draw
- Conclusion

Also Nzewi (2001) identified certain factors for teachers' use of analogy in Nigerian classrooms.

- (1) Use analogies drawn from student's environment that also are familiar to students.
- (2) Engage students in the formation of analogy.
- (3) Use discussion to guide the students on use of analogy.
- (4) Differentiate between the target and the source of the learning.
- (5) Sequence analogy for easy application

A typical example of analogy is circulation of water aquarium (circuit) and electric circuit.

Water Aquarium-----	Electric Circuit
Water-----	Electricity
Flowing water-----	Electric current
Pipes-----	Wires
Pump-----	Battery
Pressure-----	Voltage
Filter-----	Poor conductor
Reduce flow-----	Resistance

Source: Glynn, Law, Gibson & Hawkins (2014)

Secondly, process of burning is analogy of respiration, the arrangement of grapes and their stems is similar to the arrangement of alveoli and bronchial tubes in the lungs, the functions of the various part in a school system is similar to the functions of some cell parts.

3.6.1 Advantages of Use of Analogy

1. Analogy enables information (knowledge) to be transferred from familiar based to unfamiliar target.
2. Analogy can be used to introduce new lesson
3. The use of analogy helps to increase students' imaginative abilities thereby enhancing their understanding of the concept
4. Analogy helps to provide motivational support for learning
5. It helps student to generate new ideas
6. It also aids in transfer and application of knowledge
7. The base as well as the target is all examples of larger knowledge structure.
8. Analogy helps students to retrieve information stored in the memory thereby enhancing retention of information
9. Analogy helps in making the understanding of concept much clearer.

3.6.2 Disadvantages on Use of Analogy

1. The use of analogy requires a lot of carefulness otherwise it becomes a waste of time
2. In some situations, it is very difficult for students to provide the analogy required for the concept
3. It is not in every situation that is possible to provide a good analogy.

Self-Assessment Exercise 4

- | |
|--|
| <ol style="list-style-type: none">1. What do you understand by analogy in biology teaching?2. Mention one advantage and one disadvantage of use of analogy in science teaching. |
|--|



3.7 Summary

In this unit, we have learnt that:

1. Concept mapping is a schematic device for representing a set of concepts, embedded in a framework of preposition.
2. There are some advantages and disadvantages of the use of concept mapping as a teaching strategy
3. There are also certain suggestions made to guide the teacher on the use of concept mapping
4. Constructivism is a kind of learning strategy that lays emphasis on active role of learners in the process of constructing their own knowledge
5. There are some advantages and disadvantages on the use of constructivism based learning strategy

6. Focus group discussion is a tool used for collecting information from members of a group through discussions
7. There are some guidelines that will help the biology teacher in conducting focus group discussion
8. There are some advantages and disadvantages of focus group discussion.
9. Analogy is a teaching strategy that helps the teacher to relate the old ideas we already know to new ones we are yet to know.
10. There are some advantages and disadvantages on the use of analogy in teaching biology



3.8 References/Further Readings/Web Sources

- Thomas M.D., David H. Jonassen (2012) *Designing Environments for Constructive Learning*. Springer Publishing Company.
- Diana Laurillard (2013). *Rethinking University Teaching: A conventional Framework for the Effective use of Learning Technologies*, Oxon; Routledge Falmer Publisher.
- Glynn, S. N, Law M., Gibson, N. M., Hawkins, C. H. (2014). *Teaching Science with Analogies: A Resource for Teachers and Textbook Authors*.
- Else, M. J., Ramirez, M. A., Clement, John (2016). *When are Analogies the Right Tool? A Look at the Strategic Use of Analogies in Teaching Cellular Respiration to Middle-School Student*.



3.9 Possible Answers to Self-Assessment Exercises

SAE 1

Concept mapping is a diagrammatic representation of a concept using arrows to indicate their relationship in order to recreate new knowledge.

Advantages:

1. It highlights key concepts in any topic and links them sequentially.
2. It improves understanding by laying emphasis on the major concepts.

Disadvantages –

1. Every map reflects the extent of knowledge of the Mapper

SAE 2

Three principles of constructivism –

1. It structures learning around primary contents
2. Seeking and valuing students' view points
3. Assessing students learning in the context of teaching

Advantages-

1. Helps in assessing students understanding of any topic.
2. Students are actively involved since it is a child-centered learning approach.

SAE 3

To organize a focus group discussion the following must be provided/stated

- the number of students to be involved
- venue for the discussion
- questions to be asked
- time to be used
- topic to discuss
- objectives of the discussion
- appropriate equipment

Advantages –

1. It provides insight into what the students know and those yet to be known.
2. It is useful in ascertaining students aspirations, needs and experiences.

SAE 4

Analogy is establishing similarity between dissimilar objects.

Using objects that are familiar to compare unfamiliar ones that the teacher wants the students to learn.

Advantage - It can be used to introduce new topics.

Disadvantage – It can be very difficult for students to provide the analogy for some concepts.

UNIT 4 MODERN TECHNIQUES OF TEACHING BIOLOGY II

Unit Structure

- 4.1 Introduction
- 4.2 Learning Outcomes
- 4.3 Problem Solving in Biology Teaching
 - 4.3.1 Advantages of Problem Solving Strategy
 - 4.3.2 Disadvantages of Problem Solving Strategy
- 4.4 Games and Simulations in Biology Teaching
 - 4.4.1 Advantages Games and Simulations
 - 4.4.2 Disadvantages of Games and Simulations
- 4.5 Cooperative Learning in Biology Teaching
 - 4.5.1 Advantages of Cooperative Learning
 - 4.5.2 Disadvantages of Cooperative Learning
- 4.6 Summary
- 4.7 References/Further Readings/ Web Sources
- 4.8 Possible Answers to Self-Assessment Exercises



4.1 Introduction

In this unit, we examine other modern techniques of science teaching. Such techniques include problem solving, game and simulation and cooperative learning. All these techniques require active participation of the learner in the learning process.



4.2 Learning Outcomes

By the end of the unit, you should be able to:

- Explain problem solving approach in biology teaching
- Mention some of the steps involved in problem solving
- State the advantages and disadvantages of problem solving
- Explain the meaning of games and simulation in biology teaching
- state their advantages and disadvantages
- Explain the use of cooperative learning in biology teaching
- State their advantages and disadvantages.



4.3 Problem Solving in Biology Teaching

Problem solving can be defined as a method of obtaining an answer or solution to a given problem situation. Dorner (1979) defined problem solving as the transformation to surmount the barrier between the

starting situation and the final goal. Problem solving is an everyday encounter in the lives of human beings. It ranges from simple problem situation to problems that are so complex in nature. Hence, problem solving approach is an activity oriented learning in which the best result is obtained from an unknown subject through certain set of conditions. In problem solving, the learners' ability to transform the barrier between the starting position to the final goal or solution is very important and this is what is called problem solving because the learners have arrived at a solution.

Oraifo (1997) noted that the teaching of science (Biology inclusive) through the use of problem solving helps to strengthen science teaching. This is because problem solving help student to be personally involved in carrying out both mental and manipulative skill acquisition. In a classroom situation, problem solving that is supported by the teachers instruction enhance students' achievement in biology. Problem solving is a valuable tool for teaching and learning of biology. It increases student imaginative thinking in the use of reasoning to solve problems. Problem solving can be categorized into three different levels namely:

1. What is unknown?
2. The difficulty situation
3. What information can be obtained from the situation?

In the first level, the learner is concerned with the cause of the problem. In order words, the learner may start the existing problem situation with certain hypothesis.

In the second level, the learner tackles the problem situation but not necessarily with the person who poses the problem. At the final level, the learner examines the information that was given initially. This information is used to reason critically on the issues surrounding the problem. Certain tentative solutions may emanate from the problem.

There are different models or strategies involved in problem solving. These models have different stages or steps which the learner undergoes before arriving at the solution to the problem. Some of these models have stages or steps ranging between three to five depending on who propounded a particular model. For example Polya in his model propounded in 1957 has four namely.

1. Understanding the problem.
2. Devising a plan
3. Executing the plan.
4. Reviewing the solution.

Also Paschal Leone in his model propounded in 1969 has only three steps namely:

1. Figurative -This involves reading and interpreting the problem.
 2. Executing -In the case, it entails devising a solution plan.
 3. Operative -This involves carrying out the operations.
- Furthermore, Ausubel in 1990 and Gagne in 1977 also propounded five step models. There is provision for reviewing the solution to the problem in some models while in other; it may not necessarily be present.

To ensure that the learner understand the problem, implies that the learner must acquire the basic knowledge, understand the conditions associated with the problem as well as its basic goals to be achieved. These issues are very important because to understand the problem to a large extent is dependent upon how clear and accurate the learner makes meaning from the problem situation. Hence, the teacher should guide the students to acquire relevant information necessary to solve a particular problem.

Secondly, the students' ability to investigate the problem and arriving at solutions which may led to solving the problem. At this stage, the problem may be tackled from different perspectives. The use of instructional resources like charts, models, equipment, specimen etc. may be necessary at this stage and also application of logical reasoning is very important.

Finally, students review the various solutions in order to arrive at the answer or solution to the problem. Problem solving involves a series of operations which may require some skills. The ability to solve a particular problem with minimum steps increases its accuracy. A large number of steps in problem solving are highly time consuming.

4.3.1 Advantages of Problems Solving Strategy

1. Problem solving help students to be highly logical, creative and analytical in their thought and decisions.
2. With problem solving, abstract concepts which may be beyond our common sense reasoning could be tackled effectively.
3. It creates opportunities to handle individual differences among learners.

4.3.2 Disadvantages of Problem Solving Strategy

1. Problem solving is highly time consuming especially when the steps involved are so many and the topic is abstract to students.

2. Continuous application of problem solving in a classroom situation may discourage some students from participating in the lesson.
3. Some dull and low range ability students may find it difficult to cope with the lesson and as a result may not solve any problem.

Self-Assessment Exercise 1

1. Mention some steps involved in problem solving strategy
2. Mention one advantage of problem solving method in biology teaching

4.4 Games and Simulations in Biology Teaching

This is one of the modern techniques of biology teaching. A game can be regarded as a structured activity with a set of rules for the play involving two or more number of students, who interact towards achieving certain objectives. On the other hand, simulation is a working representation of the actual thing involving students in a kind of role play. Hence, it can be described as a working representation of reality in which the process may be simplified. According to Encyclopedia of Education (1964) a simulation in an operating model reproduction or social phenomena consisting of a set of interrelated variables which function in the same way as the actual system.

Simulation enables students to explore things when the reality may be too difficult, expensive, dangerous, too fast or too slow to process. Simulation possesses a high "degree of similarity with the reality in a reduced form. In games, the participants take decisions portraying the picture of actual situation in an enjoyable manner yet involving competition as well as specified rules.

In simulation, there may be no competition involved or a winner emerging rather a changed condition may be achieved by the various participants. In some situations, the two terms may be complied to have simulation games. This is an activity which reflects both decisions making as well as real life elements of simulation.

4.4.1 Advantages of Games and Simulations

1. Both uses tactics and strategies which originate from the participants.
2. Simulations and games involve active participation of students in decision making which is geared towards solving a particular problem.
3. Games and Simulations yield surprising results with students of low academic ability.
4. They help in the development of effective domain.
5. Games and simulations help students to learn and acquire the importance of decision making.

6. Games and simulations help to boost retention of information among students.
7. It enables the students to be proficient in the learning process when they are able to stay longer on a particular task.
8. Games and simulations enable students to practice new skills and be able to transfer such knowledge in a risk free environment.

4.4.2 Disadvantages of Games and Simulations

- (1) Games and simulations are usually time consuming and cannot be used to cover the syllabus.
- (2) In some situations, it may be difficult to use games and simulation in teaching certain concepts.
- (3) It slows the pace at which some intelligent students might wish to go in the learning process.

SELF ASSESSMENT EXERCISE 2

1. Mention two advantages of using the games and simulation method
2. Name two disadvantages of games and simulation in biology..

4.5 Cooperative Learning in Biology Teaching

Cooperative learning can be defined as a situation in which small teams or groups of students with different intellectual abilities engage in a variety of learning activities in order to enhance the understanding of a particular concept or topic. In other words, it can also be seen as one in which the goals of each individual are linked together with that of the others so that there is a positive correlation in the attainment of these goals. Hence an individual student obtains or seeks an outcome that is beneficial to every member of the group. Each member of the group engages in an activity not only for the purpose of learning but also encouraging each other's learning. Here students work together until they have successfully completed their group work.

In cooperative learning, all the members of the group seek mutual benefit so that every member gains from each other's support. They work and discuss the solution to their problems through explanation, listening and encouraging each other by providing academic help.

There are certain characteristics of cooperative learning, which include:

Group Heterogeneity

The size of each group is usually between 4 -6 students. Each group should be composed of both male and female students in mixed schools, different levels of academic ability, race, social status etc.

Group Objectives

Each members of a group is geared toward achieving certain objectives. To this effect, every member of the group works very hard in order to achieve these objectives by supporting each other's learning.

Equal Opportunities for Success by Group Members

Due to the heterogeneous nature of the group, every member of the group interacts positively among members. To this effect, every member of the group will be given equal opportunity to participate actively within the group.

Increasing Interpersonal Skills

Interpersonal skills in group activities are enhanced by use of cooperative learning. Such skills may be skills in leadership qualities, good oral communication, decision making and skills in management of conflict which may arise among group members as a result of differences in opinion.

Promotes Interaction

There is great positive interdependence among members of a group. Students help each other to overcome problems by involving in peer tutoring, exchange of ideas or materials, challenging each other's views and opinions. All these help them to be highly motivated in the learning process.

4.5.1 Advantages of Cooperative Learning

1. Cooperative learning promotes students' learning thereby enhancing academic achievement.
2. Cooperative learning helps to increase students' retentive memory on the topic.
3. Helps in the development of certain skills like oral communication skills.
4. Help to boost self-esteem among students.
5. With cooperative learning, students are highly motivated in their learning process.
6. Students foster mutual responsibility among members while working with cooperative learning.
7. Using cooperative learning, students learn to be patient with each other.
8. Cooperative learning experiences promotes greater interpersonal attraction between different ethnic groups.

4.5.2 Disadvantages of Cooperative Learning

Some students may find it difficult in using adapting cooperative learning strategy.

1. Some weak students may hide under the bright students and are not actually contributing in the lesson.
2. Some bright students may be deprived the opportunity to move as fast as they may want to go in the learning process.
3. It is time consuming. It cannot be used for large content coverage of the syllabus.

Self-Assessment Exercise 3

- | |
|--|
| <ol style="list-style-type: none">1. Explain the use of cooperative method in biology teaching2. Mention some of the advantages of cooperative learning.3. List some of the disadvantages of cooperative learning. |
|--|



4.6 Summary

In this unit, we have learnt other modern techniques of biology teaching which include problem solving, games and simulations and cooperative learning.

Problem solving is a method of obtaining answer or solution to a given problem situation.

Three advantages and three disadvantages were highlighted under problem solving.

A game is regarded as a structured activity with a set of rules for the play and involving 2 or more number of people.

Simulation is a working representation of the actual thing involving students in a kind of role play.

There are eight advantages and three disadvantages in games and simulations.

Cooperative learning is a situation in which small groups of students with different intellectual abilities engage in a variety of learning in order to enhance the understanding of that particular concept.

There are eight advantages and four disadvantages of cooperative learning.



4.7 Reference/Further Readings/Web Source

Encyclopedia of Education 2017.

Domer, D. (2017). *Problem Solving and Information Processing*.
Stulgart Germany Standard Psychology Publishing

Greiff S., Molnar Andreas, Funke (2013) *Journal of Educational Psychology*, Vol 105 (2), American Psychological Association.
Zimmerman, Corinne; Croker, Steve (2014) *Jornal of Cognitive Education and Psychology. A prospective Cognition Analysis of Scientific Thinking and the Implications for Teaching and Learning* Vol 13, No 2, 2014 pp. Springer Publishing Company.
Visit www.study.com .



4.8 Possible Answers To Self-Assessment Exercises

SAE 1

Steps involved in problem solving method in biology teaching-

- Reading and interpreting the problem
- Devising a solution to the problem
- Carrying out the operation
- Reviewing the solution to the problem

SAE 2 Advantages of Games and simulation-

1. Games and simulation helps in development of affective domain
2. It involves the active participation of students in deciding solutions to particular problems

Disadvantages-

1. It is time consuming and does not lead to coverage of the syllabus.
2. It slows down the pace of learning for the intelligent students.

SAE 3

Cooperative learning is a situation whereby students are grouped into 4 - 6 to engage collectively in learning activities. The group is usually heterogeneous. The students possess different intellectual abilities and they work for the mutual benefit of the group.

Advantages of Cooperative learning method –

- It helps to boost self- esteem among students.
- Helps to increase students' retention of a topic
- It fosters mutual responsibility among the students in the learning process.

Disadvantages –

- It cannot be used for large content coverage of the syllabus.
- Weak students may hide under the bright ones and will not make any contribution.

MODULE 2 RESOURCES AND PLANNING FOR BIOLOGY TEACHING

Unit 1	Resources for Teaching Biology: Teaching Materials/ Aids and Community Resources
Unit 2	Textbooks in Teaching Biology: Selection and Use
Unit 3	Improvisation in Biology Teaching
Unit 4	Teaching Units and Unit Planning
Unit 5	Lesson Preparation and Lesson Plan

UNIT 1 RESOURCES FOR TEACHING BIOLOGY: TEACHING MATERIALS/AIDS AND COMMUNITY RESOURCES

Unit Structure

- 1.1 Introduction
- 1.2 Learning Outcomes
- 1.3 Meaning of Resources
- 1.4 What is Teaching Materials or Aid?
- 1.5 Importance of Teaching Materials/Aids
- 1.6 Classification of Teaching Materials/Aids
- 1.7 Types and Functions of Teaching Materials
 - 1.7.1 Visual Materials
 - 1.7.2 Audio Materials
 - 1.7.3 Audio-Visual Materials
- 1.8 Community Resources
- 1.9 Summary
- 1.10 References/Further Readings/Web Sources
- 1.11 Possible Answers to Self-Assessment Exercises



1.1 Introduction

It is a truism that learning is essentially a social process and teaching is only an instrument of learning. It therefore becomes necessary that a teacher should use all types of machinery in guiding students' learning and these machineries that can be used in guiding learning are called instructional or teaching materials/aids. Teaching/instructional materials/aids come under resources for teaching and learning. Teaching/learning resources are many and varied covering a range of objects, facilities, processes, locations and human, from which teachers/learners can obtain information to meet their teaching/learning needs. For a biology teacher, these resources are indispensable tools in his/her hands for the achievement of the objectives of teaching. In this

unit, we are going to consider some of the resources for biology teaching, specifically, teaching materials and community resources.



1.2 Learning Outcomes

By the end of the unit, you should be able to:

- State the meaning of resource
- Explain what teaching/instructional materials are
- State the importance or value of teaching materials
- Classify teaching materials
- Enumerate the types and functions of various teaching materials
- explain what community resources are.



1.3 Meaning of Resources

Resources in teaching/learning process include anything or anybody to which or whom a teacher or a learner can turn for information or help. Thus, you have teaching and learning resources. Some of these are human resources e.g. teachers, doctors, nurses etc. materials resources e.g. chalkboard/white board, textbooks, magazines etc. Books e.g. reference materials, textbooks, magazines etc. non-printed materials e.g. pictures, drawings, etc. community resources e.g. farms, hospitals, etc. These resources are indispensable to good science (biology) teaching and learning.

1.4 What is Teaching Materials or Aid?

Teaching material or aids are those equipment and materials that a teacher uses to illustrate, emphasize and explain a lesson in order to make it clearer to the students. These materials and equipment range from simple familiar objects that can be obtained from the environment to the sophisticated ones usually produced in industries which cannot be locally obtained. Teaching materials are also referred to as instructional materials or teaching aids. It should be noted that instructional materials/aids are not and cannot be supplanted for the teaching process itself.

1.5 Importance of Teaching Materials/Aids

The values or importance of teaching materials can be summarized as follows:

- (a) They provide the teacher with the means of expanding the horizon of experience of the students, thereby seeking to provide a counterpart of first hand experience.

- (b) They can be used to illustrate some theories, or introduce lessons or at any point in time during the teaching period to drive the point home (e.g. a teacher can spray perfume in front of the class while teaching the concept diffusion in biology).
- (c) They appeal to all the senses (sight, hearing and touch etc) of the learner.
- (d) They arouse the interest of the students by creating variety which helps to sustain their attention. For instance, using dissected rat or bird to explain the alimentary tract/canal of animals.
- (e) Teaching materials help to provide materials and opportunity for experiment. This ensures students participation in the lesson, which promotes effective learning.
- (f) They create lasting impression in the mind of the learners, thereby inducing longer retention of the idea or concept being taught.
- (g) They assist the teacher to overcome the physical difficulties of presenting subject matter or topic by mere verbalization.
- (h) Teaching materials create room for discussion and interaction among students and between them and the teacher, thereby creating a conducive and friendly classroom situation
- (i) They widen the range of student's experiences by helping them to learn through several media. For instance a picture or diagram of male and female reproductive organs can be shown after teaching human reproduction. This can be followed by oral overhead projection of reproductive processes from a film or from slides.
- (j) Teaching materials induce observations and questions which are signs of quest for information and knowledge.
- (k) They reduce the boredom of verbal presentation of concepts and make room for variations in teaching strategies.

1.6 Classification of Teaching Materials/Aids

Teaching materials are classified into three broad categories, according to the sense they appeal to. These include:

- (1) **Visual Materials:** Those that appeal to the sense of sight e.g module, specimens, charts, still pictures, overhead transparencies etc.
- (2) **Audio Materials:** Those that appeal to the sense of hearing e.g human voice, record player, radio, tap recorder, audio tape, language laboratories etc.
- (3) **Audio-visual Materials:** These are materials that stimulate both the senses of sight and hearing simultaneously e.g television, film projectors, sound motion pictures, video, tapes, audio -strips (transparency), audio-pictorial (printed materials with recorded sound), audio-slides, study trips and demonstrations.

1.7 Types and Functions of Teaching Materials

1.7.1 Visual Materials

(i) **Chalkboard (Black/white board):** This is one of the most useful visual aids for effective teaching of biology. The teacher uses it to illustrate verbal presentations in a sequential and orderly manner. It also allows for point to point explanation, building from simple to complex. It allows the teacher to integrate other teaching materials (e.g. charts, maps, diagrams) into his/her lesson at the right time, to emphasize the contents involved. The chalkboard can be used to introduce a topic, highlight important aspects of the topic, and illustrate diagrams, test questions, assignments or any other information that will facilitate visual presentation.

The chalkboard has the disadvantage of now allowing eye to eye contact between the teacher and the learners. This may lead to disruptive behaviours in the students especially when the teacher backs the students while writing or drawing.

(ii) **Charts:** Charts are visual representative of diagrams, cartoon, graphs, a card board with letterings, used to introduce or summarize points, issues or concepts of a lesson. Charts of different cells (plants and animal), organs (heart, kidney, liver etc) and systems (digestive, respiratory, excretory etc) can be displayed to serve as additional visual aids. They can be prepared locally or industrially. Industrially prepared charts are more durable and can be used over a long period of time. Charts present facts and information in few words thus helping learners to grasp the key points of the concept. It has a dual purpose of allowing easy view of what is presented as well as sustaining student's attention. Charts however have the disadvantage of being expensive if prepared for commercial use. It lacks motion and depth and may not represent the actual size of the object being portrayed.

(iii) **Models:** Models are modified version of the real objects or things. Examples include models of human heart, skeleton, kidney, ear, eye and cell. They can be made from plastics, clay, paper mash, plasticine, copper, wood etc. A creative teacher can make models for his teaching or guide the students into making different models for teaching/learning purposes.

Two types of models are: scale or semi-scale and diagrammatic models. Scale models like pictures, illustrate teaching points e.g models of animals (dogs, lion, cat etc) Diagrammatic models are presented in form of diagrams ego model of sky, rainbow, shadow etc. Models have the advantage of presenting objects in three-dimensional form thereby presenting a better picture of reality of concept than two-dimensional pictures. When students participate in constructing models, their creative abilities are enhanced and they get the excitement of achievement. They

also provide source of amusement and entertainment to the students. They facilitate learning by stimulating and drawing the attention and interest of the students.

Models however have the disadvantage of lacking details and being difficult to construct.

They may lead to misconceptions of facts or ideas being prevented if not properly constructed.

(iv) **Soft Board/Display/Bulletin Boards:** These are large plywood boards or level cord boards displayed in the classroom or any other strategic place where flash cards, posters etc are pasted. They are mainly for display of information that is relevant to the students. They are used to arouse/sustain interests in science (biology). Usually, relevant science (biology) information are cut out and pinned to these boards for everybody to see. The biology teacher can use it for teaching different types of insects by collecting and pinning them on the board on different days of the week. In addition, these boards:

Save time, allowing students to interact with materials outside the teaching periods.

Encourage active involvement of students in the study of specific concepts or sequence of events. Help students in learning to communicate ideas visually.

Serve as catalyst to teaching/learning by making the environment dynamic, relevant and attractive.

(v) **Flannel Boards or Feltboards:** This consists of a stretched inexpensive cotton flannel wood over a flat panel of plywood or a hard heavy card-board. The surface is made up of adhesive materials where materials can be pasted for study. It can be used for teaching a variety of concepts especially those that involve step by step presentation. It is used for discussion, especially during drilling periods. It creates opportunity for students' participation and promotes their creativity. Flannel boards enable the teacher to explain a concept and build it up with visual illustrations as the lesson progresses. Examples-stages in the life cycle of an insect e.g. cockroach, phases of mitosis or meiosis etc.

(vi) **Specimens:** These are collection of real objects or things as teaching materials. In biology, specimens of plants and animals are collected and used for instructional purposes. They are collected from within the environment and are therefore not expensive. A biology specimen can be a whole organism or its part. They can be life (fresh) or preserved specimens. Example include: cockroach, lizard, bird,

mouthparts of an insect, bones of the skeleton, a whole plant or its part (leaf, root, stem) etc.

They arouse students' interest and promote meaningful learning of concepts. They are however limited by the fact that their collection is energy and time consuming.

Secondly, they are not applicable to all teaching situation where other resource materials are available. For instance, a film or overhead projector of the stages in the life cycle of a housefly is better than trying to collect the various stages for observation in the class.

(vii) **Textbooks** -will be discussed in the next unit.

1.7.2 Audio Materials

Audio materials include the following:

(i) **The Radio:** Radio is the commonest and cheapest audio materials. Useful for teaching a large number of students especially when the intention is to reach a large group in remote areas and isolated schools. Educational radio programmes discuss interesting topics and some difficult concepts that are of general importance. They provide additional learning materials for students.

(ii) **The Record Player:** This is used to record instructions on wax records and playing them back on demand. This is not common in schools because educational materials are usually not waxed for school use.

(iii) **The Tape Recorder:** Tape recorders enable the users to play back recorded information/instruction at one's convenience. In biology classroom, tape recorders can be used to record and play back the teachers' verbal presentation of a lesson, talk from a resource person (e.g. Doctor) etc. In a classroom learning situation, tape recorder can be actively used when the teacher encourage the students to provide their own learning materials and listen to themselves as well as others. When the learner listens to only recorded materials, they are using the tape recorder passively.

1.7.3 Audio – Visual Materials

These include television, video films, motion pictures with sounds, CDs etc. Television programmes on school subjects ego biology can be utilized by the teacher as effective teaching aids. Students can be advised to tune to educational programmes in the evenings at their various homes in urban areas. The biology teacher can also bring to the class, videotaped lesson(s) on particular topics of interest (e.g cell

division -mitosis and meiosis animal reproduction etc). Through television, students can look and enter into the privacy of places such as hospitals, breweries and other industries. The use of video cassettes/films, motion pictures with sounds and CDs for biology instructions helps the teacher to create the impression of real life scenarios that facilitate teaching -learning process.

The motion pictures in films and CDs produce a strong and lasting impact on biology students since they get emotionally involved in the action of the films. Activities of wildlife in their natural settings can be brought into the classrooms through video, films and CDs.

1.8 Community Resources

The community can provide valuable resources for biology teaching. It may either serve as a source of learning or a place where what is learnt can be applied. Community resources can therefore be referred to as those teaching and learning resources that can be got from the environment or community where the school is located. They include persons of the community with specialized knowledge or expertise (eg doctors, nurses, agriculturist etc.) industries, research institutions, zoological and botanical gardens, wildlife, parks/games reserve, museums, hospitals, maternities, aquatic environments (e.g. streams, rivers, ponds, lakes, beaches). Community resources are generally cheap and are easy to procure. This is because people or industries/organizations will be willing to render services to their community schools. Through such services, students have the opportunity and privilege of interacting with experts in various fields thus gaining greater insight into their science learning. When students are exposed to real life situations, they learn faster and understand better, the concept being taught. Use of community resources in teaching also fosters better relationship and co-operation between the school and the community.

A biology teacher can organize a visit to a nearby hospital/maternity to enable student's watch doctors/nurses attend to patients. Students' visit to a local farm to observe the cultivation, planting or harvesting of crops by farmers, will make learning of agricultural concepts in biology exciting and fun. Such visits can also be used to initiate studies on different types of soils, the climate, and use of fertilizers, control of pest and disease of plants. It can also challenge the students to start off their own school farm where they would practice the act of individual farming, thus having first-hand experience in growing crops.

Students could also be made to visit sites of biological importance like community erosion sites, refuse dumps, sewage treatment plants/sewages, zoological gardens etc depending on what is available in the community

and according to the biology concept being taught. In this way the children are brought face to face with reality and link is established between school work and the community of the school.

Community resource is limited as a teaching resource because it is time consuming, difficult to plan and execute.



1.9 Summary

In this unit, the concept of teaching materials and community resources were discussed in relation to biology teaching and learning. The types, importance and classification of instructional/teaching materials/aids were highlighted. It was clearly stated that when biology teachers appropriately apply teaching materials and community resources in teaching biology, that students will not only understand better the concepts being taught but will also be stimulated to learn more. They will also be willing to relate what they learn within the school to life and activities outside the school premises.

Community resources will in addition to facilitating learning, bring about cordial relationship and mutual understand between the school and the community where the school is located thus fostering unity and peace in too community.

Self-Assessment Exercise 1

1. Why are teaching materials/aids important?
2. Which of these is not an audio-visual material –A. Television B. Radio C. Videos D. Film projector



1.10 References/Further Readings/Web Resources

Zimmerman, Corinne; Croker, Steve (2014) *Journal of Cognitive Education and Psychology. A prospective Cognition Analysis of Scientific Thinking and the Implications for Teaching and Learning* Vol 13, No 2, 2014 pp. Springer Publishing Company.

Edward W. Sarath (2013) *Improvisation, Creativity and Consciousness*: Sunny Press pp487.

Nnaka, C. V. (2003) *Selection and Use of Learning Resources*, In *Methodology of Instruction*, p.68-74 G. C. Unachukwu (Ed.) Totan Publishers

Boosting Resources Utilization in Biology Classrooms. STAN Conference Proceeding 2000.



1.11 Possible Answers to Self-Assessment Exercises

SAE 1

1. Teaching materials are important for the following reasons-

1. They create room for discussion and interaction
2. They induce observations and questions from students
3. They appeal to the senses of sight, hearing and touch of the students.

2 Answer is B –Radio

UNIT 2 TEXTBOOKS IN TEACHING BIOLOGY: SELECTION AND USE

Unit Structure

- 2.1 Introduction
- 2.2 Learning Outcomes
- 2.3 Meaning and Classification of Textbooks
- 2.4 Qualities of Good Biology Textbooks
- 2.5 Guidelines for Selecting Biology Textbooks
- 2.6 Uses of Biology Textbooks
- 2.7 Limitations of Biology Textbooks
- 2.8 Summary
- 2.9 References/ Further Readings/Web Sources
- 2.10 Possible Answers to Self –Assessment Exercises



2.1 Introduction

Textbooks are one of the important tools of learning for students and of teaching for teachers. Sometimes they are used as the only source of securing information. At many other times or situations, they become the course of study for the subject. Considering these practices, it becomes necessary that textbook selection be thoughtfully made for biology teaching as in other science subjects. The text materials should be broad and inclusive, involving not only basic texts but also supplementary materials to provide breadth and depth. The varieties of biology textbooks displayed on the market shelves and bookshops stress the need for selection. Some of the books are written by "hungry authors" who lack indepth knowledge of the subject matter and are only interested in making money. This calls for caution on both teachers and students on the biology textbooks they use as a source material.

In this unit, qualities of good textbooks especially those of biology will be considered. The guidelines for their selection as well as their usefulness and limitations will be highlighted.



2.2 Learning Outcomes

By the end of this unit, you should be able to:

- State what textbooks are and how they can be classified.
- Outline the qualities of a good textbook
- Enumerate the guidelines for selecting biology textbooks

- List at least four uses of textbooks each for the teacher and the students
- State the limitations of textbooks for biology teaching and learning.



2.3 Meaning and Classification of Textbooks

Textbooks can be defined as materials employed by schools or college students and teachers as standard work on a particular skill or subject. They are designed for classroom use with appropriate vocabulary, illustrational, student exercises and teacher guides/aids. They cover a wide range of subjects and levels of education.

Textbooks can be classified into three categories namely:

- (a) **Based textbooks:** These function as the chief source of information for students' study of a given subject.
- (b) **Co-basal textbooks:** -These are used with other textbooks as the main study of a particular subject.
- (c) **Supplementary textbooks:** These are used to supplement information provided by basal and co-basal textbooks.

2.4 Qualities of Good Biology Textbooks

A good biology textbook should possess the following qualities:

- (1) **Accuracy/correct information**-The concepts, principles, facts etc. presented must be scientifically correct.
- (2) **Coherence**-Materials presented must be clear and simple to facilitate understanding.
- (3) **Readability**-The language of the textbook must be appropriate and within the reach of the students for which it is intended.
- (4) **Illustrations**-Illustrations have to be clear and simple.
- (5) **Coverage** -The textbook must have adequate coverage in relation to the objectives of the course and the subject matter has to be treated in detail.
- (6) **Availability** -The text must be easily available.
- (7) **Clarity** of presentation, quality of prints and attractiveness of the text must be assured.
- (8) The textbook must have suggested activities, study questions, summaries etc.
- (9) **Cost:** The textbook has to be affordable to both teachers and students.

2.5 Guidelines for Selecting Biology Textbooks

Biology textbooks abound in the market shelves but not all of them are effective in meeting the teaching and learning needs of teachers and students. Because of this, care should be taken in selecting some of these books. The following guidelines should be considered while selecting biology textbooks:

- (1) **Scope or Content:** The following questions should be asked about the scope or content of the book:
 - (a) Does the textbook treat the topics to be covered in the course? If so, is the depth and breadth of the treatment adequate?
 - (b) Is the author competent or qualified in the field (biology)?
 - (c) Does the author have any particular bias or orientation to the subject? If so, is the bias or orientation acceptable in your school system?
 - (d) Does the writing have good style?
- (2) **Treatment:** The following questions should be addressed under treatment:
 - (a) Are style and vocabulary suitable for the age and class level of students who will use the textbooks?
 - (b) Does the text have complete index and table of contents? If so, are they easy to use?
 - (c) Are the illustrations correct and of good quality?
 - (d) Will the illustrations appeal to students of both sexes? (e) Are aids provided for slow learners?
 - (f) Are extra challenges provided for more talented students?
 - (g) Are summaries provided? If so, are they appropriate?
 - (h) Does the text provide enough exercises for practice?
- (3) **Mechanical Features:** The teacher should ask the following questions:
 - (a) Is the print clear and readable? (b) Is the print large enough?
 - (c) Is there enough spacing between the lines? (d) Are the lines of proper length?
 - (e) Is the paper of good weight and durability?
 - (f) Is the binding strong and reinforced so that the book is held finally in its cover?

The table below shows how textbooks can be evaluated for selection as an instructional tool.

Table 1: Sample Rating Scale for Evaluating Biology Textbooks

Instruction: Rate each book on the items listed below on a 5-point scale as follows:

1- Unsatisfactory, 2 -poor, 3 -fair, 4 -good, and 5 -superior

As an Instructional Tool

Title -1, Title- 2 ,Title - 3 ,Title-4, Title- 5, Title-6, Title-7 ,Title -8, Title-9

- 1 How well does the book archive the objectives of biology?
- 2 How well does the book give satisfactory coverage to subject matter?
- 3 How satisfactorily is the organization of materials for effective learning and for course of study?
4. How clearly is the material written?
5. How effective is the material for student's interest?
6. How appropriate is vocabulary and style of presentation for students for whom intended?
- 7 . How accurate and up to-date are contents?
8. How helpful to learning process are the illustrative materials?
9. How adequate are the study aids, suggested activities, bibliographies and other teaching aids?
- 10 How adequate are the examination questions and suggestions for practical work?
- 11 Has the book glossary, index and appendix?

Comments

Recommendations in order of Preference:

1. ---

2. ----

3. ----

4. ----

Date----- ---Examiner----

Source: Owen, A.M. In Anderson, H.D. (2006).

2.6 Uses of Biology Textbooks

From the start point of the teacher and students, the textbook is the most important teaching aid and an essential tool for effective learning. Although it has many advantages, textbooks should never replace the teacher in the teaching/learning process. The students should also not regard textbooks as the only source of information for their course. The textbook is useful in the following ways:

(a) For Teachers:

- i. Helps them to organize, unify and diversify instructions. They provide planned activities and common reading material before hand for a given class level. They are also graded so that when introducing new concepts or content, they go from simple to complex and from concrete to abstract.

- ii. Helps to improve their skills through teachers manuals, practices and introductions. Since they are written by experts, they often suggest guidelines for teaching specific topics or units.
- iii. Assists the teacher to prepare his/her lessons, offers him/her facts, ideas, experiments, diagrams etc. which have been properly collected, arrange and discussed. It sometimes directs him/her on the limit/depth of teaching, suggests methods of approaching/presenting a particular topic. A good biology textbook reduces the efforts put in teaching work.

(b) For the Students:

- i. The biology textbook aids learning by providing valuable information about the concept of discussion.
- ii It increases their knowledge and induce further reading. The summarizes at the end of the chapter helps to improve students' understanding.
- iii. Some biology textbook with activity exercises help the students to be actively involved in the teaching/learning process thereby increasing objective and reflective thinking.
- iv. Textbooks also enable students to proceed at their own rate and to some extent according to their own interest. The exercises, study questions and practice materials at the end of the chapters or book, help in self-evaluation of the students' progress.

2.7 Limitations of Biology Textbooks

Biology texts may have the following disadvantages or limitations:

- (a) It promotes rote learning: The textbooks encourage cramming without any critical thinking. The learner reads to remember rather than doing his/her own organization and thinking.
- (b) Teacher may become lazy: Many teachers rely on textbooks as the only source of information. Some teachers only assigned pages to be read, followed by tests and examinations. Some make no efforts to read or explain the materials to the students. Some do not even care to adopt exercises and activities to the learner's interests and needs.
- (c) Text materials may be out-dated: As man's knowledge of subject increases from day to day, textbooks also need to be revised from time to time. Many biology textbooks have been revived to meet the needs of the time.
- (d) No single textbook is effective in class instruction. Effective instruction requires that the teacher consults several textbooks. Again, no single textbook is good for all students because of individual differences.
- (e) Some biology textbooks are poorly written, lacking in both content and quality. Some are full of grammatical flaws and misrepresentation of diagrams, illustrations, concepts and facts.

This makes it difficult for the reader to understand or make sense of the writing

Based on the above limitations, the following guidelines for using textbooks effectively have been suggested (Uche and Umoren, 2015):

1. Textbooks should be used in such a way that relate to what the learner is studying (biology in this case).
2. Courses content of texts should cater for individual growth of the learner and their skills development especially in terms of problem solving abilities.
3. The teachers should provide and plan for co-operative activities and varieties using textbooks in collaboration with other materials.
4. The text used should provide concrete experiences. They should contain pictorial illustrations and perhaps colour to arouse and sustain the attention and interests of the student.
5. The chosen text should be in accordance to the readability level of the learners. The textbooks should be written in words, vocabularies and languages that are equivalent to the age and interest of the student.
6. Selection of textbooks should not be based on sentiments but on value, quality and significance in terms of imparting scientific knowledge and understanding.

Self-Assessment Exercise

- | |
|---|
| <ol style="list-style-type: none">1. Mention any four qualities of a good biology textbook2. State three limitations of using textbooks in teaching biology. |
|---|



2.8 Summary

- Textbooks in the context of school are materials used by teachers and students as standard work on particular subject or skill. Textbooks are classified as basal, co- basal and supplementary according to the level of usage.
- A good biology textbook must give correct information, be clear in presentation of facts, readable, of wide coverage, available and affordable.
- The selection of biology textbooks must be based on certain criteria such as scope or content, coverage, treatment and mechanical features.
- As an instructional tool, a biology textbook has to be carefully selected by the teacher bearing certain facts in mind. Textbooks have many uses for both teachers and students. Teachers through them are able to organize their lessons, improve their skills and get exposed to unlimited information about the course. For the students, textbooks not only provide

- information but also aid learning and enable them to proceed at their own pace.
- Textbooks are limited in that they address the entire audience thereby neglecting individual differences. It can also lend itself to abuse or misuse by poorly prepared or motivated teachers.



2.9 References/Further Readings/Web Sources

Thomas M. Risk (2015) *Principles and Practices of Teaching in Secondary Schools*

Uche, S. C and Umoren, G. U. (2015). *Integrated Science Teaching: Perspectives and Approaches.*

Selecting Science Textbooks, Archie M. Owen in Hans O. Anderson (2017). *Reading in Science Education for Secondary Schools.*



2.10 Possible Answers to Self-Assessment Exercises

SAE 1-

Qualities of a good textbook-

1. Readability - the language used in writing the textbook must be appropriate for the level of students it is meant for.
2. Availability – the book must be easily available
3. Clarity of Presentation – e.g. the print should be clear
4. Clear and simple illustrations.

Limitations –

The textbook materials may be outdated/obsolete Textbooks need to be reviewed to incorporate new knowledge.

It encourages rote learning and cramming without thinking.

Some textbooks are poorly written, lacking content and quality.

UNIT 3 IMPROVISATION IN BIOLOGY TEACHING

Unit Structure

- 3.1 Introduction
- 3.2 Learning Outcomes
- 3.3 Definition of Improvisation
- 3.4 Rationale for Improvisation in Biology Teaching
- 3.5 When do you improvise?
- 3.6 Considerations for Improvisation
- 3.7 Importance of Improvement
- 3.8 Limitations of Improvement
- 3.9 Summary
- 3.10 References/Further Readings/Web Sources
- 3.11 Possible Answers to Self-Assessment Exercises



3.1 Introduction

The teaching of science including biology cannot be effectively done without allowing interaction between the students and the environmental resources (both material and equipment). The science curriculum is also planned to enable the teacher use activity -oriented, child-centered approach (guided inquiry) to teach. However, evidences from research have shown that materials and equipment for teaching science are either not enough or are completely lacking in schools to the extent that most teachers end up with verbal exposition of scientific principles, facts and concepts. The verbal exposition does not promote skill development, objectivity and critical thinking abilities that will enable the child to function effectively in the society. This makes the need for alternative sources of teaching materials and equipment inevitable. The environment of the school as well as the homes of students provide rich sources of these materials and a resourceful teacher can on his own or with the help of students and other members of the society, improvise these materials for teaching purposes. This unit will examine the concept of Improvisation as it concerns biology teaching and the various ways the biology teacher can use improvised materials and equipment to bring about meaningful learning of biological concepts in the students.



3.2 Learning Outcomes

By the end of this unit, you should be able to:

- Define improvisation conceptually
- State the rationale for improvisation in biology
- state when to improvise

- Outline the considerations for improvisation
- List some materials or equipment that can be improvised in biology
- List four importance of improvisation
- Outline the limitations of improvisation.



3.3 Definition of Improvisation

Improvisation in the context of biology can be defined as the process of using alternative resources for enhancing biology teaching in the absence or shortage of the real ones. The production of the alternative resources is initiated by the teacher and done either by him or by local craftsmen (e.g. carpenters, blacksmith, welders etc.). The teacher may also use the students for improvising some of the needed materials or equipment. Other definitions include those of Bomide (2016) and Olagunju (2020) who described improvisation as the act of using materials or equipment obtained from the local environment or designed by either the science teacher or with the aid of local personnel to enhance instruction. Furthermore, Uche and Umoren (2015) defined Improvisation as the process of making something one has not prepared for, because a sudden need has arisen.

From the above definitions, one can rightly infer that, Improvisation has direct link with classroom instruction and is a teacher-centred activity which ensures that the items improvised work as intended. Improvisation comes into play when there is an urgent need for resources that will facilitate understanding of classroom instructions.

3.4 Rationale for Improvisation in Biology Teaching

The need for improvisation arises as a result of the following:

- (1) To achieve one of the main objectives of science education namely: to develop in the student's problems solving and manipulative skills, scientific attitudes, interests and appreciation.
- (2) To serve as alternative resources (materials and equipment) where they are not locally available.
- (3) Reduce cost where some of the equipment and materials are available local
- (4) To develop the creative and technical skills of teachers, students, local craftsmen, technicians and technologists.
- (5) Supplement the available resources to meet the demands of large student population.
- (6) Conserving foreign exchange through promotion of utilization of local resources.

3.5 When do you improvise?

The biology teacher needs to improvise when:

- (1) Resources (materials and equipment) are scarce and can be substituted with local ones.
- (2) The available materials or equipment are unaffordable due to high cost and the improvised one can serve the same purpose.
- (3) There is need to promote technological transfer through encouraging creativity using environmental resources.
- (4) There is an urgent need to replace damaged equipment in order to continue class activities.
- (5) Teaching becomes ineffective and boring due to lack of materials and equipment.

3.6 Considerations for Improvisation

Buchi (1987) stated that science teachers should:

- (i) Examine the lesson content and consider the following before embarking on improvisation specific lesson objectives for the week, month and term.
- (ii) Identify standard equipment or apparatus needed to achieve the above objectives.
- (iii) Check the equipment store to see if the standard equipment/material is available. If not, consider the possibility of improvisation.
- (iv) Use their initiatives to construct or substitute the lacking equipment, using the available materials.

The list of some improvised equipment and materials for teaching biology are presented in the table 3.1 below.

Table 3.1: Some biology equipment and materials and their improvised options

Table 3.1: Some biology equipment and materials and their improvised options

EQUIPMENT	IMPROVISED OPTIONS
Bunsen burner	Candle, oil lamp, lamp kerosene and kerosene stove
Beakers	Tumblers, milk containers
Measuring cylinder	Babies feeding bottle
Reagent bottles	Bottles of cough syrup and maltex
Petri-dishes and watch glasses	Lids of jam jars
Troughs	Plastic bowls
Hand lens	Magnifying or reading glass

Insect net	Circular stiff wire with mosquito netting at the end and held by a small wooden pole.
Materials	
Iodine, sugar and salt	Can be purchased locally
Animal specimens e.g Fish, frigs, birds, toads rats, lizards e.t.c Earthworms, roundworms, tapeworms and snails	Can be obtained locally an preserved in 10% formalin. Can be obtained locally an preserved in 5% formalin
Plant Specimen e.g. leaves and flowers	Can be obtained locally an preserved by drying in newspapers.
Aquatic plants	Locally obtained and preserved in natural water.
	Maize grains glued with plasticine
Chromosome, DNA model	Local gin (ogogoro)

Note: 5 part ogogoro in 90 parts of water will serve as 10% formalin.

Improvised materials can be in form of models and used for teaching specific concepts in biology e.g. Models of the heart, kidney, ear, eye etc. respiratory system can be modeled using local materials and used to demonstrate breathing moments in some animals.

In such models, the trachea is represented by a rubber tube: AT-joint formed from the rubber tube represent the bronchi, balloons attached to the T -joint represent the lungs,

A bell jar represent the thoracic cavity and

A rubber sheet at the end of the bell represents the diaphragm.

A hard working and resourceful biology teacher will be able to not only achieve science skills but also sensitize and develop same in the students.

3.7 Importance of Improvisation

Improvisation is important for the following reasons:

- It ensures better understanding of the concept taught by the students
- It promotes students interest and encourages participation in the teaching/learning process.
- Enhances teachers' and students' creativity and resourcefulness Encourages use of environmental and locally produced resources. Brings real life situations into the classroom environment.
- Reduces dependence on imported resources thereby cutting down cost.

- Helps to widen inquiry, curiosity and fruitful application of knowledge.

3.8 Limitations of Improvisation

Improvised resources have the following limitations or disadvantages:

- Limited accuracy -The accuracy of improvised materials will be limited compared to that of the real one.
- Requires special skill and resourcefulness on the part of the teacher.
- Demands extra time for planning and execution.



3.9 Summary

In this unit, we have learnt that:

- (i) Improvisation is a teacher centered process that allows the use of alternative local/environmental resources to enhance biology instruction in the absence of the real one.
- (ii) Improvisation is embarked upon in order to develop in the students problem solving and manipulative skills, scientific attitudes, interest and appreciation, which are the main objectives of science education.
- (iii) Teachers improvise when the real materials are lacking/scarce, expensive and when the environment is rich with local resources that can serve as a substitute to real ones.
- (v) Biology teachers have to consider the contents and objectives of the lesson in line with what is available for teaching before Improvisation is important because it not only promotes understanding of the concepts being taught but also enhances teachers' and students' creativity and resourcefulness.
- (vi) Improvisation is limited in terms of reduced accuracy and demand on time

Self-Assessment Exercise 1

1. What do you understand by the term improvisation?
2. List some of the materials and equipment that can be improvised for biology teaching.
3. Why is improvisation important for biology teaching. .



3.10 References/Further Readings/Web Sources

- Olagunju, A. M. (2016). *An Investigation into Teachers' Attitude towards and extent of Improvisation of Resources for Effective Teaching of Biology*. 41st Annual Conference of STAN. Awka.120 -125.
- Zimmerman, Corinne; Croker, Steve (2014) *Journal of Cognitive Education and Psychology. A prospective Cognition Analysis of Scientific Thinking and the Implications for Teaching and Learning* Vol 13, No 2, 2014 pp. Springer Publishing Company. Boosting Resources Utilization in Biology Classrooms. STAN Proceeding 2000
- Bomide, G. S. (2017). *Science Teaching in the Period of Recession. The Need for Improvisation*. JSTAN. 23 (1&2). 182 -186.
- Bichi, S.S. (2016). *Improvisation in Teaching Primary Science*. A Paper Presented at STAN National Workshop on the Teaching of Primary Science at A.T.C. Zaria.
- Gabanja, S.P.T. (2011). *Modern Methods in Science Education in Africa*. Owerri: Totan Publishers .



3.11 Possible Answers to Self-Assessment Exercises

SAE 1

1. Improvisation means providing alternative resources in the absence of the real one.
2. List of some materials that can be improvised include- Bunsen burner, Beakers, measuring cylinders, Hand lens, Reagent bottles, Insect net, Formalin, Plant and animal specimen etc.
3. Why is improvisation important? -
 - To supplement the available resources to meet the demand of large student population.
 - To conserve foreign exchange through promotion of utilization of local resources.
 - To develop scientific attitude, manipulative and problem solving skills in the students.

UNIT 4 TEACHING UNITS AND UNIT PLANNING

Unit Structure

- 4.1 Introduction
- 4.2 Learning Outcomes
- 4.3 Concept of Planning
- 4.4 Curriculum
- 4.5 Syllabus
- 4.6 Scheme of Work/Teaching Unit or Plan
 - 4.6.1 Guidelines for Drawing Scheme of Work/Teaching Plan
 - 4.6.2 Format for Writing Scheme of Work
 - 4.6.3 A Sample Scheme of Work of Five Weeks
- 4.7 Unit Plan
 - 4.7.1 Format for Writing a Unit Plan
 - 4.7.2 A Sample Unit Plan
- 4.8 Summary
- 4.9 References/Further Readings/Web Sources
- 5.0 Possible Answers to Self- Assessment Exercises



4.1 Introduction

The aim of science teaching is to facilitate the understanding of scientific concepts being taught in schools. The achievement of the broad aims and objectives of science teaching is the responsibility of the teacher. The teachers' goal therefore will be to improve his competence in teaching science in the classroom so as to assist students to learn and understand the basic scientific concepts. In order to accomplish this task, the science teacher not only plans, but also determines appropriate objectives for the students; devises strategies that would enable students to achieve the objectives; implements the strategies; and determine their effectiveness in accomplishing the set objectives.

Planning of what to teach and how to get about teaching it is paramount in the heart of every competent science teacher. A competent teacher is one who understands the place of learning experiences in the total curriculum, carefully plans and systematically varies students learning. This the teacher does by planning his daily lessons from a pre-planned scheme of work which is a reflection of his/her understanding of the syllabus and the total curriculum organization. From the scheme of work, units are drawn and taught according to the level of the students and the specifications of the syllabus and the curriculum.

This unit shall discuss the concept of planning with emphasis on teaching units and unit.



4.2 Learning Outcomes

By the end of the unit, you should be able to:

- Explain what planning is
- Say what a teaching unit or scheme of work is
- Define a unit plan
- State the major components of a unit plan
- Write a unit plan covering four lessons or more.



4.3 Concept of Planning

Planning in the teaching/learning context includes everything the teacher does before engaging in actual teaching. It may include the following:

- The objectives the teacher sets out to achieve
- The activities/roles to be played by different groups during the teaching process.
- When and how to play such roles strategies to adopt in teaching and
- Methods of evaluation of teaching outcomes.

The success of any unit depends to a large extent on the preparedness of the teacher and he skillfulness with which he/she accomplishes it.

Planning enables science teachers to do the following: -

- Prepare well in advance the topics to teach & materials/tools for teaching them,
- Strategies to be employed and evaluation techniques to use.
- Teach with confidence.
- Avoid rush or haphazard teaching of the lesson.
- Evaluate their teaching and to determine the success or failure of his/ her previous efforts.

This brings about innovation in teaching/learning process as the teacher employs new strategies to ensure the achievement of the set objectives, map out their intentions and tactics in terms of subject content, objectives, methods and evaluation procedures to effectively manage their classrooms.

The total plan of instruction consists of the following components: -

- The curriculum
- Federal or State Syllabi
- Scheme of work
- Unit of lessons /teaching unit/plan
- Daily lesson notes.

As was stated earlier, this unit will concentrate on scheme of work and unit of lessons. The preparation and planning of lessons notes will be treated in the next unit. For clarity, the curriculum and syllabus will be briefly described to show the link between them and the unit of our discussion.

4.4 Curriculum

The curriculum is the channel through which educational institutions translate societal aspirations with concrete reality. It can be defined as all the planned and guided learning experiences, designed by the school to achieve predetermined educational objectives (Uche and Umoren,1998).

It is prepared by the Federal Ministry of Education to cover specific primary or secondary school subjects. Hence you have core curriculum for biology, chemistry or primary science as the case maybe.

4.5 Syllabus

The syllabus is a curriculum guide used by schools for specifying which subject to the taught. It is drawn from the larger curriculum, subject by subject. The science syllabus for instance, should provide details of what should be taught in all science subjects (biology, chemistry, physics etc) on the curriculum at various levels during the academic year, a semester or a term. The contents of the science syllabus is drawn by joint efforts of Educationists, Curriculum Specialists, Ministry of Education Officials, Examination Bodies (e.g. WAEC and NECO) Professional Science Associations (e.g. STAN), University Teachers and Researchers etc.

4.6 Scheme of Work/Teaching Unit or Plan

A scheme of work/teaching unit consists of units, topics, concepts and themes to be covered in a specific period of time. It is drawn from the syllabus and it shows an overview of the course content for the year, a term or week by listing in sequence the units and topics to be covered. It is from this scheme or teaching unit that the classroom teacher plans particular lesson(s) to be taught within particular period(s). The scheme of work is usually prepared by a team of science teacher with the head of science department.

SELF-ASSESSMENT EXERCISE 1

- | |
|---|
| <ol style="list-style-type: none">1. What are the components of a teaching plan?2. What is a Syllabus? |
|---|

4.6.1 Guidelines for Drawing Scheme of Works/Teaching Plan

The following guidelines should help the teacher in drawing the scheme of work:

Concepts from the syllabus should be arranged sequentially according to their relationship with each other, with simpler concepts preceding complex ones.

Teacher ensures that adequate periods are assigned for teaching the concepts in each class.

Teacher should take cognizance of interruption by public holidays, manual labour or any other special event (e.g. inter-house sports). Plans and prepares the scheme of work with other teachers in the same subject area and the head of department.

The teacher should make allowance for revision and examination. Teacher should incorporate practical work in the scheme so as to relate theory with practice.

Although the scheme of work is the teacher's personal plan to cover the syllabus, it should not be rigidly followed especially where students find the concept difficult to comprehend. The scheme of work should be made as flexible as possible to accommodate individual differences of the students. The teacher should also apply his/her creative talents and past experiences in developing the scheme of work.

4.6.2 Format for Writing Scheme of Work

Name of School

Name of

Teacher Date

Class.....Subject

Unit Number and Title

A. Topic (i)

Content to

be covered with a specified number of weeks

(a).....

(b)

(c)

(ii) Link with other subjects (integration)

(a).....

(b).....

(c).....

B. Performance Objectives

Assist students to perform activities which would enable them to: (a)

.....

(b) (c)

.....

C. Equipment and Materials

List the equipment and materials that would enable students carry out the activities and achieve the stated objectives.

D. Activities enable them to:

Derived from the content as specified in (a to c) above within a certain number of weeks.

E. Continuous Assessment and Record Keeping

(a) Revision and Test/Quiz

(b) Keep appropriate record against each student's name.

(c)

4.6 .3 A Sample Scheme of Work of Five Weeks

For Senior Secondary Two (SSII) Biology

A. Topic: Respiratory system and Respiration in plants and animals.

Second Term

Week 1 – 5 (1) Respiratory Systems

(2) Mechanism of respiratory systems

(a) Higher animals (b) Lower animals (c) Plants

(3) Cellular/Tissue respiration B. (1) Content:

(i) Respiratory system

(ii) Definition

(iii) Types of respiratory systems e.g. body surface, gills, trachea etc.

(2) Mechanism of Respiratory Systems

(i) in higher animals

(ii) in lower animals

(iii) in plants

(3) Cellular/Tissue Respiration

(i) Definition

(ii) Anaerobic respiration (catabolism) (iii) Anaerobic respiration (iv) Energy release during respiration

(ii) Link with content of other subjects (integration) Burning/combination of fuel in physical systems e.g. automobiles. Conversion of potential energy to kinetic energy.

B. Objectives Assist students to perform simple activities that would (1) In Respiratory Systems

(a) Observe and draw some respiratory surface e.g. lungs, gills, stomata, trachea e.t.c

(b) Open up the organisms having these respiratory surfaces to identify their common features.

- (2) Mechanism of Respiratory System
- (a) Feel the respiratory movements of the ribs and the diaphragm during inspiration and expirations.
- (b) Observe respiratory movements using model
- (3) Cellular/Tissue Respiratory
- (a) Demonstrate anaerobic respiration in yeast
- (b) Aerobic respiration in small/mammal e.g. rat.
- (c) Illustrate the major steps involved in the Krebs's Cycle.
- C. Equipment and Materials

Dissecting sets, respiratory jars, thermos flasks, conical flasks, bell jars, bean seeds, yeast, a small mammal e.g. rat, model of ribs/thoracic cavity, model of lungs, diaphragm, trachea etc., fish, earthworm, cockroach, charts on different respiratory surfaces.

D. Activities (Weeks 1 -5)

Respiratory Systems

- (1) Using the dissecting set, open up the animal provided (lizard, rat or bird) to expose the lungs.
- (2) Observe the body surface of the earthworm
- (3) Cut open the fish or an insect to expose the gills under the operculum and the trachea in insects.
- (4) Make diagrams of some of the respiratory surfaces e.g. lungs, gills or trachea.

Respiratory Mechanism

- (1) Draw the diagram of the thoracic cavity from a chart
- (2) Feel the movement of the ribs and the diaphragm while breathing in and out with their palms.
- (3) Make diagrams of the stomata from the chalkboard-showing

Its opening and closing Cellular/Tissues Respiration

1. Students carry out experiments to show: (i) Anaerobic respiration in yeast.
 - (ii) Aerobic respiration in small mammals e.g. rat. (iii) Energy release during respiration.
 2. Draw diagram of the Krebs's Cycle (simplified form).
 3. Students discuss the differences between breathing and cellular respiration.
 4. Discuss the rate of the energy released during cellular respiration.
- E. Continuous Assessment

Revise the work from week 1 to 5 and test to determine whether the students actually learnt the concept.

Respiratory System:

1. Define the terms respiration.
2. List five respiratory surfaces indicating the organism that use each
3. List any four characteristics of respiratory surfaces. Mechanism of Respiratory System:

Mechanism of Respiratory System:

1. Where are the lungs located?
2. Describe what happens during inspiration and expiration.
3. Describe how either a fish or an insect respire.
4. How does exchange of gases occur in the leaf of a plant.

Internal/Tissue Respiration

- (1) What is tissue respiration?
- (2) Write out three differences between aerobic and anaerobic respiration.
- (3) What are the major steps involved in the Krebs's Cycle.
- (4) Describe an experiment to show either anaerobic respiration in yeast or aerobic respiration in rat.

The result of the continuous assessment test will determine whether the teacher should proceed to a new topic or re-teach the concept. Each student's record is kept against his/her name or all the tests given within the term.

4.7 Unit Plan

According to Uche and Umorem, (2012), a unit is a part of a syllabus incorporating broad content area of interrelated topics. A unit plan therefore is a teacher's preparation for teaching a particular topic or a set of related topics. It may include two or three lessons or the lessons for a number of weeks according to the scope and sequence of the topic. The main purpose of a unit plan is to place the daily lessons into broader perspective and at the same time, force a deeper analysis of the content to be taught (Maduabam, 2014).

4.7.1 Format for Writing a Unit Plan

Teacher Class
Topic

..... No. of Lessons

1. Introduction- state briefly what the unit is all about and its importance
2. Main ideas and processes: Outline the major content to be taught and the duration.
3. Behavioural objectives: list student's expected outcomes ie the specific learning they are expected to achieve.

4. Instructional materials: make a list of all the instructional materials to be used.
5. Statement of learning activities: list appropriate learning activities deemed necessary for the attainment of the objectives. A brief summary of the procedures and techniques should highlighted.
6. Number and title of daily lesson plans
7. Method of assessment: specify tests that would be included with the daily plans
8. Assignment: this should include reinforcement and application exercises, drills etc
9. Suggestion for modification of the Unit (how the success of the unit will be determined).

4.7.2 A Sample Unit Plan

Teacher Class.....
 Topic
 No. of Lessons.....

A. Introduction: To enable the students to acquire the correct conception of 'living' by studying the biological characteristics of living organisms, the students should be able to contrast living and non-living things and should see themselves as part of the living world. Identify the sun as the ultimate source of energy and identify of her sources of energy.

B. Content: (Main ideas to be demonstrated or revealed)

-Biological inquiry -nature and role; scientific process/method; living and non-living things and organization of life.

C. Objectives: Students would be expected to be able to do the following:

- Carry out simple observations
- Identify scientific problems of biological nature
- Formulate and test hypotheses
- Plan experiments under controlled conditions. Gather and interpret data
- State the characteristics of living things
- Differentiate living thing from non-living things
- Distinguish between plants and animals.
- Classify living things into major groups
- Identify and describe levels of organization of life.
- Infer implications of the different levels to the study of 'differentiation' and 'specialization' in organisms
- Give examples of levels of organizations
- Identify the major forms and sources of energy

- State the first and second laws of thermodynamic

D. Instructional Materials: Varieties of living and non-living things e.g. plant materials, animals, stones, wood, water, paper etc. microscope, slides (plain and prepared), hand lenses/magnifying glasses etc.

(E) Learning Activities: Students would be expected to do the following:

- (a) Make observation of specimens (live and dead) of plant and animals.
- (b) Make some generalizations
- (c) Plan and carry out controlled experiments.
- (d) Identify several variables in the experiments.
- (e) Identify problems encountered and propose solutions to them.
- (f) Collect, observe/identify many living organisms and state their characteristics
- (g) Make certain generalizations about the organisms (e.g classify or describe)
- (h) Identify and classify non-living things in the surroundings
- (i) Stress interrelations among living things
- (j) Carry out microscopic examination of organisms from different levels of organization
- (k) Discuss the significance of different levels of organization led by the teacher.
- (l) Find out or discuss the following: why we need energy how we get the energy we need relationship between food and energy
- (m) Teacher leads a discussion on the first and second laws of thermodynamics

F. Number and Title of Daily Lessons

The unit has six lessons: Biology as inquiry

Process and method of science; usefulness of science.

Living and non-living things: characteristics and classification

Organization of life

Complexity of organization in higher organisms -advantages and disadvantages

Major sources and forms of energy -energy requirements; first and second laws of thermodynamics. G. Evaluations

Students will be asked questions based on the objective of each day's lesson.

Self-Assessment Exercise 2

- | | |
|----|---|
| 1. | State 3 guidelines for drawing a scheme or work |
| 2. | What is a Unit Plan? |



4.8 Summary

The highlights of this unit include:- The teacher is responsible for achieving the broad aims and objectives of science teaching.

In order to succeed, the teacher not only plans but also determines the objectives to be achieved, the how and means of achieving the objectives as well as the extent to which he has achieve it. Teaching unit and unit plan are strategies that aid the teacher to break or organize his/her work according to duration, age and level of the students.



4.9 References/Further Readings/Web Sources

Fundamental of Teaching Practice by John V. Okorie(2015). Integrated Science Teaching - Perspective and Approach , Uche S. C. and Umoren, G. U.(2012)

Biology Curriculum for Senior Secondary Schools by the Federal Ministry of Education.(2013)



4.10 Possible Answers to Self-Assessment Exercises

SAE 1

1. Components of a teaching unit consist of Units, Topics, Concepts and Themes to be covered in a specific period of time. They are drawn from the syllabus.

2. A syllabus is a curriculum guide used by schools for specifying the subjects that should be taught.

SAE 2 Three guidelines for drawing up a scheme of work

1. Arrangement of concepts in a sequential order according to their relationship.

2, Ensure that adequate periods are assigned for teaching the concepts in each class.

3 Make allowance for revision and examination

UNIT 5 LESSON PREPARATION AND LESSON PLAN

Unit Structure

- 5.1 Introduction
- 5.2 Learning Outcomes
- 5.3 What is a Lesson Plan?
- 5.4 Rationale for Preparing and Planning Lesson
- 5.5 Essential Steps in Preparing a Lesson Plan
 - 5.5.1 Advantages of Lesson Plan/Note
- 5.6 Sample Lesson Plan/Note for SSI Biology
- 5.7 Summary
- 5.8 References/Further Readings/Web Sources
- 5.9 Possible Answers to Self- Assessment Exercises



5.1 Introduction

Teachers prepare to teach their lessons in order to facilitate classroom activities and to guide their presentation of concepts in a logical and sequential order. In order to achieve these, the teacher packages all he/she needs to do, how he/she wishes to do them, as well as what the students ought to do, into a lesson plan or lesson note.



5.2 Learning Outcomes

By the end of the unit, you should be able to:

- State what lesson plan is
- Highlight the rationale for preparing and planning lesson
- Specify the essential features of a lesson plan
- List at least five advantages of lesson note
- Write a lesson note using a specific bio logical concept.



5.3 What is a Lesson Plan?

A lesson plan is a representation of the teacher's preparation for a specific lesson or series of lessons. It is normally a plan for teaching a class, a job or a lesson. Lesson plans are essentially a teacher's plan of action. It specifies what the teacher wants to teach, how long to teach it. Lesson plans vary from teacher to teacher, depending on the concept being taught, the materials available for teaching it, the community resources, the age and class of the students concerned. A lesson plan should include the following:-

- the name of the lesson

- the objectives for the lesson
- the equipment and materials needed
- the subject matter or problem for study and discussion (content)-
the procedure for attaining the objective references

A lesson plan may be brief or detailed depending on the experience of the teacher and what he wants to accomplish in a particular lesson.

5.4 Rationale for Preparing and Planning Lesson

Preparation and planning for lessons are necessary because of the following:

1. They enable the teacher to perceive a broad picture of the materials to be studied over a given time period.
2. Help the teacher to state the objectives in measurable terms
3. Enable the teacher to assess pre-requisite skills of students.
4. Enable teacher to identify and acquire supplementary instructional materials.
5. Help teacher to identify and utilize appropriate teaching strategy.
6. Enable the teacher to give appropriate assignment and to check supplementary materials or references.

A successful teacher ensures that he/she plans the progress of his/her students from the beginning of the class or session to the end. Effective utilization of the available time should be the priority of every conscious teacher.

Self- assessment Exercise 1

1. A lesson plan consists of the following except – A. Objectives B. Procedure for achieving the objectives C. Equipment D. Marking scheme
2. Mention any 4 rationale for preparing a lesson plan.

5.5 Essential Steps in Preparing a Lesson Plan

The following steps should guide the teacher in preparing a lesson plan:

- (a) Stating the objectives of the lesson -the teacher has to state in behavioural terms what he/she intends to achieve from teaching the lesson. He/she has to constantly refer to the objectives in the cause of developing the lesson.
- (b) Motivational techniques to be used to arouse students to learn. Motivation can be in form of a question, a story or an anecdote.
- (c) List of instructional materials or equipment needed for the lesson.
- (d) Points of emphasis should be listed so as to remind the teacher of their importance in the teaching/learning process.

- (e) Choice of appropriate method/methods which will make teaching/learning clearer.
- (t) Prepare in advance questions to ask the students as the lesson progresses or at the end.
- (g) The teacher should prepare tests covering the content and objectives of the lesson and should also set a standard of achievement required of a learner for success in the test.
- (h) Teacher should prepare and plan the lesson in an orderly manner for easy reference or review.

5.5.1 Advantages of Lesson Plan/Note

Well written lesson plans/notes are valuable working tools in the hand of every teacher. It has been found that good and effective teachers are those who take time to prepare their lesson plans/note in writing and use them in teaching. Some of the advantages of using lesson plans/notes include the following:

1. A good lesson plan/note enables the teacher to carry out his/her duty effectively.
2. It increases the confidence of the teacher during lesson delivery.
3. It prepares the teacher ahead of time for the materials/equipment needed for teaching.
4. It enables the teacher to manage teaching time well.
5. Helps the teacher to avoid haphazard dissipation of knowledge.
6. Enables the teacher concentrate on particular aspects of the lesson for the day.
7. Allows the teacher to use the appropriate teaching strategies and illustrative resource materials.
8. Helps the teacher to update his knowledge on current issues in his/her subject area as he/she prepares/plans the lesson.
Instructional Strategies: Expository, questioning, activity, guided inquiry and discussion.
Instructional Materials: Microscope, prepared slides of Paramecium, Spirogyra, Euglena etc.
9. A teacher with well written lesson plan/note which he/she refers to while teaching commands respect from his students
10. Good lesson plans help beginning teachers and those who are asked to relieve a class in the absence of the class teacher.
11. It enables the teacher to predict areas of learning difficulties in the students.
12. It enhances the work of supervisors, or co-operating teachers in terms of provision of practicable and concrete directives.
13. Assist supervisors and principals in evaluating the teacher's performance.

5.6 Sample Lesson Plan/Note for SSI Biology

Name of Teacher: Subject: Biology Topic: The Cell

Class: SSI

Duration: 2 periods of 40 minutes each

Date: 03/06/2011

Content: The cell as a living unit: Forms in which living things exist.

Instructional Objectives: At the end of the lesson, the students should be able to:

1. Give examples of resonance single celled organisms that exist on their own.
2. List the characteristics of living organisms.
3. State the forms in which living cells can exist with examples.
4. State that cells living as part of an organism may be independent
5. Distinguish group of cells that form tissues from those that form colonies or filaments.

Entering Behaviour: It is assumed that the students know what microorganisms are and the uses of the microscope.

Entering Behaviour Test:

1. What are micro-organisms?
2. Give three examples of microorganisms
3. What are the microscopes used for?

Instructional Procedures:

Step I: The concept of cell was introduced to the students. The cell were said to be a unit of all living organisms and possess all the characteristics of living things.

Activity I: Students were asked to mention (recall) the characteristics of living things.

Step II: The students were told that organisms may be made up of one cell In that case, it is termed unicellular or acellular organism. This unicellular/acellular organism is capable of independent existence e.g. amoeba, paramecium, euglena etc. Activity II: Students observe and draw unicellular organisms under the microscope using prepared slides.

Step III: A cell was also said to be capable of forming part of a living organism. An organism made up of more than one cell is referred to as multicellular organism. The arrangement of the cells may vary from one organisms to another. Examples include: volvox, spirogyra, hydra, yeast etc.

Activity III: Students observe and draw multicellular organisms in their note books using microscope, prepared slides and textbooks.

Step IV: The various forms in which living cells can exist were explained and summarized as follows:

- (a) as an independent organism e.g amoeba
- (b) as a colony e.g volvox
- (c) as a filament e.g spirogyra

The cells can also be closely linked together to form tissues e.g epidermal cells of an onion bulb and inner epidermal cells of the cheek.

Performance Assessment

- (1) Give two examples of single cell organisms.
- (2) State at least five characteristics of living organisms which the cell share
- (3) State three forms in which cells can exist, giving one example of each.
- (4) Can cells living as part of organisms exist independently?
- (5) How can you differentiate between cells that form tissues from those that form filaments or colonies?

Week 2 ending 9/06/2011

Subject: Biology

Topic: Excretion

Class: SSII

Time: 2 periods of 40 minutes each Date: 2/06/2011

Content: Excretion: definition, organelles for excretion, forms of waste products and types of excreting systems.

Instructional Objectives: At the end of the lesson, the students should be to:

- (1) Define the term excretion.
- (2) List of organelles for excretion in living cells. (3) List forms in which waste products are excreted
- (4) Identify and describe different types of excretory systems in plants and animals.

Instructional Strategies: Expository, activity, guided inquiry, questioning and discussion.

Instructional Material: Charts of the kidney, lungs, liver, skin, model of the kidney, dissected insect, and not showing their excretory systems.

Entering Behaviour : It is assumed that students know that different metabolic activities in the body produced wastes, which ought to be removed from the body of living organisms. Entering Behaviour task:

- (1) Name any two metabolic wastes you know.
- (2) What happens to these wastes after production? Instructional

Procedures

Step I: A brief introduction of the concept of excretion leading to its definition. It was emphasized that the waste products removed are those of metabolism, although poisonous substances taken in with food are also removed. The process of excretion occurs in both plants and animals, although the structures involved vary in complexity.

Activity I: Teacher leads discussion on the need for excretion using leading questions.

Step II: Teacher leads students into listing the excretory products of both plants and animals e.g. carbon dioxide, waters, mineral salts, nitrogenous compounds, oxygen etc.

Activity II: Teacher leads discussion as to whether the removal of undigested food substances can be regarded as excretion and why?

Step III: The different organelles for excretion and the organisms using them were listed. The different excretory products removed by these organelles were also listed. The kidney was said to be the major excretory organ in mammals.

Activity III: The various charts of the excretory organs were displayed for students to identify and study. A dissected cockroach was displayed for students to observe and draw the malpighian tubule.

Step IV: Summary of the major points were listed on the chalk board and students were allowed to ask questions where they did not understand.

Performance Assessment

- (1) Define the term excretion
- (2) List four organelles for excretion in living cells. (3) In what forms are waste products excreted.
- (4) Name and describe anyone excretory systems in (a) plants and (b) animals.

Assignment

Read about excretory mechanisms in insects and mammals.

Self-Assessment Exercise 2

1. State three advantages of using a lesson plan in teaching biology?
2. Mention any three essential steps in planning a lesson

**5.7 Summary**

This work has tried to intimate biology teachers on the need to prepare and plan their lessons as the first step towards teacher effectiveness in the classroom. The rationale, essential features and advantages of lesson plan/note were highlighted. Sample lesson plans/notes for SSI and SSII biology were given as a guide to biology teachers. It should be noted that lesson plans are not rigid but flexible based on the topic being taught, resource available and the experience of the teacher.

**5.8 References /Further Readings/Web Sources**

- John V. Okorie (2012) *Fundamental of Teaching Practice In Integrated Service Teaching: Perspective and Approach*, Uche S. C. and Umoren, G. U(Ed.).(2012) *Biology Curriculum for Senior Secondary Schools* by the Federal Ministry. *Modern Methods in Science Education in Africa* , Sahr P.T.(2015)
- Nnaka, C.V. (2003) *Preparing Lesson Plans*, In *Methodology of Instruction*,G.C. Unachukwu (Ed.) Totan Publishers, Owerri.



5.9 Possible Answers to Self-Assessment Exercises

SAE 1

A lesson plan consists of the following except

- a) Objectives
 - b) The procedure for achieving the objectives.
 - c) Equipment
 - d) Marking scheme
2. Four rationale for preparing a lesson plan –
- Helps the teacher to state the objectives in measurable terms.
 - Helps the teacher to identify and use appropriate teaching method
 - Helps the teacher to identify and acquire teaching materials.
 - Enables the teacher to assess pre-requisite skills of students.

SAE 2

Advantages of using a lesson plan in teaching-

1. It increases the confidence of the teacher.
2. It helps the teacher to manage the time assigned for the lesson.
3. It assists supervisors and principals in evaluating the performance of the teacher.

MODULE 3 LABORATORY DESIGN, MANAGEMENT AND SAFETY

- Unit 1 Laboratory Facilities: Biology Laboratory Design
- Unit 2 Managing the Biology Laboratory
- Unit 3 Safety in the Biology Laboratory

UNIT 1 LABORATORY FACILITIES: BIOLOGY LABORATORY DESIGN

Unit Structure

- 1.1 Introduction
- 1.2 Learning Outcomes
- 1.3 Laboratory Design
 - 1.3.1 Space
 - 1.3.2 General Laboratory Ventilation
 - 1.3.3 Signs and Labels
 - 1.3.4 Storage Area/Store Rooms/Stock Rooms
 - 1.3.5 Preparatory Room
 - 1.3.6 Procurement, Distribution and Storage of Chemicals
 - 1.3.7 Services
- 1.4 Summary
- 1.5 References/Further Readings/Web Sources
- 1.6 Possible Answers to Self-Assessment Exercises



1.1 Introduction

“Laboratory” means a facility where the use of hazardous chemicals for teaching purposes occurs. It is a workplace where relatively small quantities of hazardous chemicals are used on a non-production basis. The biology laboratory can simply be described as a safe place where students, teachers and researcher carry out biological activities. In another words, biology laboratory is a state-of-the-art laboratory which provides an opportunity to carry out a variety of biological analysis and services.

In this unit we shall examine the design of the biology laboratory, and the components of the laboratory.



1.2 Learning Outcomes

By the end of the unit, you should be able to:

- Explain in simple terms, the meaning of biology laboratory
- List the essential components of a biology laboratory
- Describe in details any two of these components.



1.3 Laboratory Design

1.3.1 Space

This is one of the most important considerations in designing a biology laboratory. The biology laboratory and in fact, any laboratory should have a large space for free movement during learning activities. The specification of the shape (square, rectangular, circle) and dimension should be such that it provides more than being adequate for the proposed or estimated number of users at a given time.

The location of the laboratory should be such that bringing in supplies as well as outdoor accessibility will be easy.

1.3.2 General Laboratory Ventilation

A biology laboratory should have an adequate ventilation system with air intakes and exhausts that are capable of providing source of air for breathing and for input to local ventilation devices. The ventilation system of a biology laboratory should be such that air is constantly replaced, to prevent an increase in the air, concentrations of toxic substances during work periods. The ventilation system should also direct airflow into the laboratory from non-laboratory areas and out to the exterior of the building.

1.3.3 Signs and Labels

Every biology laboratory should bear signs and labels clearly visible and posted. These labels and warning signs should alert students, teachers, and laboratory workers to potentially hazardous materials. Safety facilities, chemical use, storage emergency equipment, emergency response personnel and exit should all have signs and labels for easy identification and safety, especially to guide first time users of the laboratory. Examples of such signs are as follows:

Where there are gallons of flammable liquid. This should bear a flammable liquid sticker visibly pasted on it, i.e. identify labels showing contents of containers and associated hazards.

In case of emergency, names and numbers of personnel to contact, e.g. fire fighters.

Location of signs for safety showers, eyewash stations, first aid equipment, exits and areas where food and beverage consumption and storage are permitted.

Warning at areas or equipment where special or unusual hazards exist

1.3.4 Storage Area/Store Rooms/Stock Room

In the biology laboratory, there should be a storage area, sometimes referred to as Storeroom. In this storage room, chemicals should be stored according to compatibility and designated by hazard classes. For example: flammable irritants corrosives low hazards oxidizers poisons. The areas where chemicals are stored should be well identified. Such chemical should be properly labeled and stored appropriately, in the area designated for it. The area should be with good ventilation. Chemicals/substances that are highly toxic or other chemicals whose containers have been opened should be in unbreakable secondary containers. In addition, these chemicals/substance stored in the storeroom should be examined periodically (at least twice in a year) for replacement, in case of deterioration and container integrity. The storeroom should be opened during normal working hours and manned by one person. It should not be used as a repackaging, demonstration or preparation room for experimental activities.

1.3.5 Preparatory Room

In addition to the storeroom, is another ancillary room where materials, apparatus, and chemical substances are prepared and assembled before they are used? This is the preparation or prep room. The following components should be included in the preparatory room:

Rack of shelves Cupboards Working platforms Benches/Stools In addition, the following services should be provided:

Functional water supply Electricity supply, and Gas source (for heating).

It is usually advisable, that the preparation room and the storeroom should be next to each other.

1.3.6 Procurement, Distribution and Storage of Chemicals

(a) Procurement

In procurement of chemicals, substances, specimens and other working materials in the biology, the store man should know information on proper handling, storage and disposal before they are received. Items without adequate identifying labels should not be accepted.

(b) Laboratory Storage

When chemicals, substances, specimens and other necessary items for the biology laboratory are procured, they should not be stored on bench tops, floors, stairways, hall ways/passages. They should be stored properly in designated areas in the store. Storage areas that expose materials to heat or direct sunlight should be avoided. Periodic inventories should be undertaken in the laboratory and the adjoining prep room, and items that are no longer needed discarded or returned to the storeroom.

1. 3.7 Services

In the biology laboratory, the provision of the following services; water, drainage, gas and electricity or source of light are essential.

Water service points should be installed at demonstration benches and on each side of the laboratory along the periphery of the room. For biology laboratory located in areas where water is scarce, it is advisable to install a storage tank at the roof level outside the laboratory. As an interim measure, water can be provided in large plastic containers

. Ideally, electricity is necessary in a biology laboratory to enable activities to be carried out effectively. Where this is not feasible, a generator can be used. Fluorescent tubes installed at strategic areas such as demonstration points/bench, in-between areas and at the back of laboratory should serve the lighting purposes of a laboratory. Where it is impossible to have electricity, the natural lighting available in the laboratory should be maximized.

Gas supply to the biology laboratory is also essential. This should be piped from a central cylinder installed outside the laboratory building. The pipes should be laid where they can easily be repaired. The handling of gas should be strictly monitored. It is advisable to have the control switch located on the teachers table so that he can control its use. When it is not possible to have gas, lamps that use spirit may be used.

Good drainage is essential in a biology laboratory. To reduce drainage problems in biology laboratory, the drains should be designed in such a way they are much wider than the diameter of the holes in the sinks that

serve them. They should also be built in such a way that all liquid are collected in a central place and removed. Closed drainages that are easy to clean are recommended.

Self- Assessment Exercise 2

1. Make a list of the essential components of a biology laboratory
2. State at least 4 services that must be provided in a biology laboratory.
- 3 Visit any nearby biology laboratory in a secondary school.



1.4 Summary

In this unit, we have learnt that:

- i The biology laboratory is a safe place where students, teachers and researchers carryout biological activities.
- ii A biology laboratory should be designed to have a large space for free signs and labels clearly visible and posted; a storeroom where chemicals, specimens and other materials for biology activities are placed or stored. Other essential needs include a preparatory room where materials, chemicals, apparatus are prepared and assembled before use. The need for proper procurement, distribution and storage of chemicals are discussed.



1.5 References/Further Readings/Web Sources

Ali Anthony, (2018). *Strategic Issues and Trends in Science Education*, Onitsha: Africa Cape Publisher International Limited.



1.6 Possible Answers to Self-Assessment Exercises

SAE

- 1 Essential components of a laboratory are –store room, preparatory room, safety facilities. Signs and labels and warning signs placed to alert students and teachers to hazardous materials.
- 2 .Essential services in the laboratory include- Water, Drainage, Gas, and Electricity

UNIT 2 MANAGING THE BIOLOGY LABORATORY

- 2.1 Introduction
- 2.2 Learning Outcomes
- 2.3 Laboratory Management
- 2.4 Management Structure
 - 2.4.1 Planning Biology Laboratory Activity
 - 2.4.2 Useful Biology Laboratory Management Techniques
- 2.5 Housekeeping and Maintenance
- 2.6 Records
 - 2.6.1 Accident and First Aid Records
 - 2.6.2 Stock Records
 - 2.6.3 Damages and Breakages Records
- 2.7 Safety Equipment
- 2.8 Summary
- 2.9 References/Further Readings/Web Sources
- 2.10 Possible Answers to Self-Assessment Exercises



2.1 Introduction

Biology laboratory management involves the arrangement and display of materials, equipment, and substances/chemicals and the organization of these in the laboratory. Procedures and practices are carried out to make the laboratory effective, and to minimize the potentials of danger to students, teachers and researchers who use chemicals/substances that could be hazardous. In this unit, we will examine issues related to biology laboratory management.



2.2 Learning Outcomes

By the end of this unit, you should be able to:

- Describe the management structure of the biology laboratory
- List some techniques used in managing a biology laboratory
- Acquire the skills needed for effective housekeeping and maintenance of the laboratory
- Ensuring the safety of all equipment and materials in the laboratory
- Keeping records in the laboratory.



2.3 Laboratory Management

Biology Laboratory management is a technique that enables the biology teacher to cope with and or co-ordinate all the complex interactions in the laboratory. They include:

- Ordering Stocking Storage
- Safety of all equipment

The biology teacher must be prepared to commit his/her professional, creative, technical, and ingenious skills readily and willingly to manage the laboratory effectively.

2.4 Management Structure

The biology laboratory management structure should have at the top, the biology teacher; the other biology teachers in other of seniority will follow him.

To assist are senior laboratory assistants followed by the laboratory, assistants/technicians and the store man. The students are usually at the end of the structure.

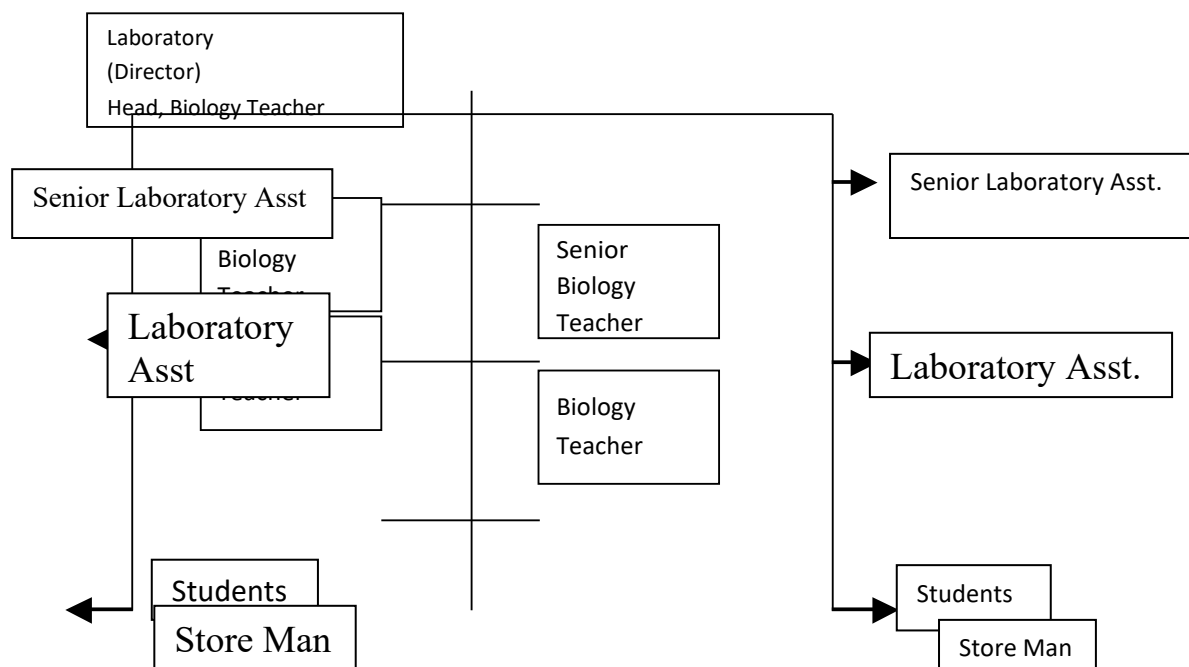

See Fig. 3.1 Biology Laboratory Management Structure

Most typical Nigerian secondary school biology laboratories consist of large rooms containing stools, benches, wall racks, shelves, specimen bottles, equipment, materials, charts diagrams and pictures on the wall. (Insert picture).

The materials /equipment, which the biology teacher and students need to work with, may not be in good working order. In addition, the number of students may be too large for the teacher to handle. With all these odds, there is the need for the biology teacher to manage the laboratory effectively. The biology teacher must therefore, carefully make a work plan with the following steps:

Work planning/preparation activities:

Work preparation by Laboratory Assistants and others. Work monitoring by biology teacher and co-teachers.

If the biology teacher follows this process, it will help him/her to manage the laboratory effectively. This is further illustrated in Fig.3.2

Fig. 3.2 Biology Lab. Plan and Execution Process

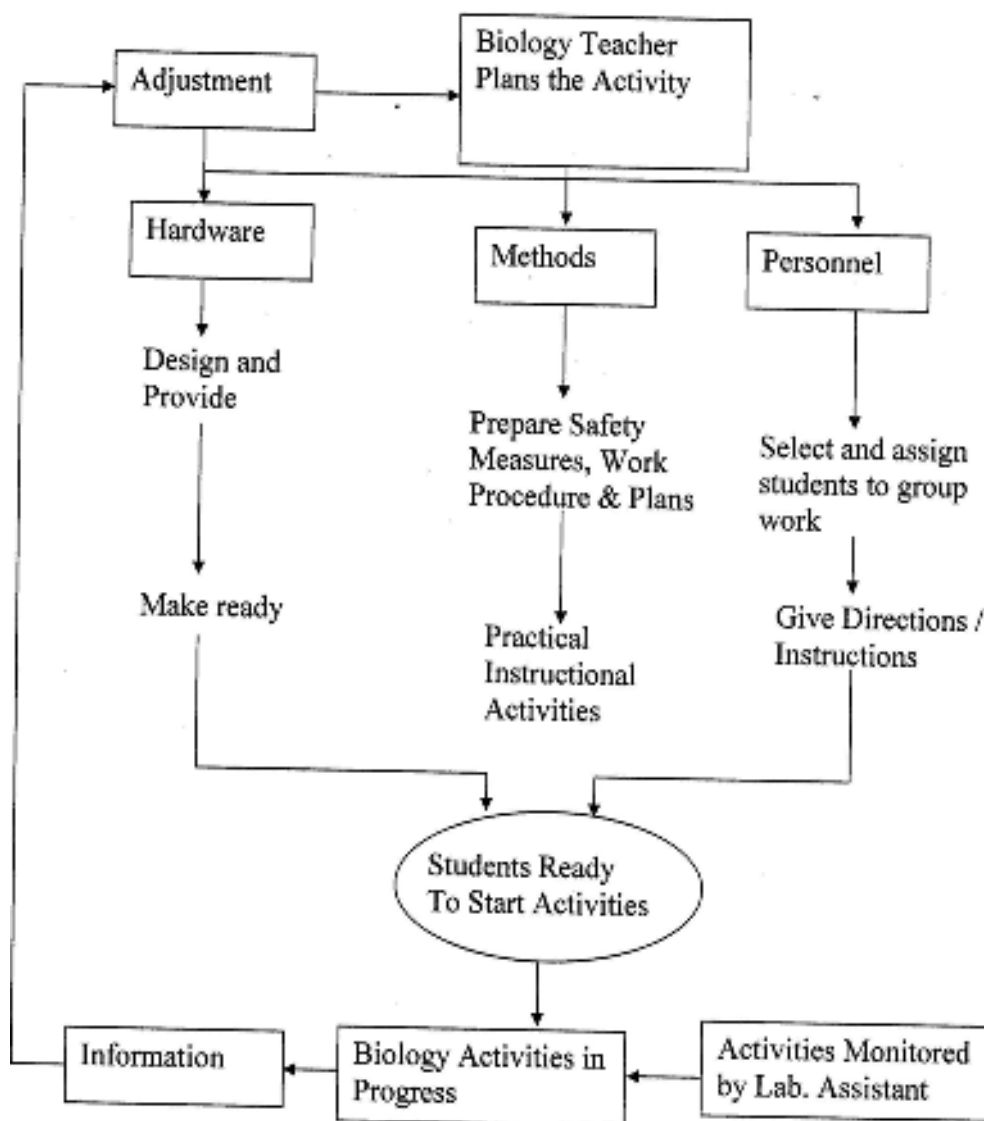

2.4.1 Planning Biology Laboratory Activity

The biology teacher should plan carefully for every biology laboratory activity he/she proposes to carry out with his/her students. The process illustrated in fig.3.2 includes knowing the materials, hardware, equipment, methods and all personnel needed for the proposed laboratory activities, and getting them ready for use. The plan should also include the safety measures, and work procedures. The laboratory activities should involve the inquiry learning, and the biology teacher should design activities that will involve open-ended problems and investigative experiences. As students carry out their activities, the biology teacher and laboratory assistants should monitor their progress and when the students need more information, the biology teacher and laboratory assistants should be present to supply such information to the students.

2.4.2 Useful Biology Laboratory Management Techniques

The following are some useful biology laboratory management techniques that may help the teacher:

- ❖ Priority placement of items that have become indispensable while making purchase
- ❖ Consideration of items to be purchased that has not become obsolete. Ensuring that items being ordered are what are delivered.
- ❖ Ensuring that the items are functionally and structurally correct as ordered before acceptance.
- ❖ Ensuring that the correct number arrived.
- ❖ Ensuring that each piece of equipment is kept in a specific place.
- ❖ Ensuring that each cupboard should bear a general label indicating the type of material it contains.
- ❖ Providing for suitably sized drawers for the storage of glassware.
- ❖ Use of stock book.
- ❖ Ensuring that all reagent bottles are labeled.
- ❖ Insisting that reagent bottles that contain volatile, toxic or combustible materials are marked with red to indicate danger.
- ❖ Ensuring that gas cylinders are stored outside the laboratory building.
- ❖ Ensuring that safety measures are adopted to prevent injury to persons and equipment.

2.5 Housekeeping and Maintenance

Cleaning

A biology laboratory should be cleaned properly. This applies especially to the floors, which should be cleaned regularly, and kept dry at all times.

Hall ways

Hallways, passages, and staircases should be cleared at all times and never be used as storage areas. Access to exits, emergency equipment, and utility controls should never be blocked.

Inspection

There should be formal laboratory keeping and chemical hygiene inspections, at least twice in a year. Informal inspection should be carried out periodically, and as often as practicable.

2.6 Records

In the biology laboratory, the habit of good record keeping is very important for effective running of the laboratory. The following records are recommended.

2.6 .1 Accident and First Aid Records

A record of such should be written and reflect all accidents. This is useful as it may reveal common sources of accidents in the laboratory by students. The teacher can then use this as a reference point for warning student. A format for accident and first aid record book is shown in Fig. 3.3.

Fig. 3.3 -Accident and First Aid Record Book

Accident and First Aid Record Book

S/No.	Name of Students Involved	Cause of Accident	Place	Time	First Aid Given	Name of First Aid

2.6 .2 Stock Records

This is sometimes referred to as inventory and usage records. This should contain every item of apparatus and high-risk substances and should be kept as specified in Fig. 3.4.

Stock Records

S/No.	Name of Item	Date of Receipt	Amount of Materials on Hand	Amount of Material Used	Name of Users

Fig. 3.4 Stock Record.

2.6.3 Damages and Breakages Records

This book is equally important in the biology laboratory. Here, broken or damaged equipment/materials are recorded to help account for missing items and for ease of replacement. It will also help to instill discipline among students/users and give them a sense of caring for and handling equipment and materials in the laboratory well. A format for keeping the damages and breakages record is shown in Fig. 3.5.

Fig. 3.5 Damages and Breakages Record

S/No.	Item Broken	Name of Student	Date	Cause of Breakage	Name of Lab. Asst. Present

2.7 Safety Equipment

For smooth laboratory management the following safety equipment must be provided:

Eye wash facilities Safety showers First aid kit Spill kit and other safety equipment.

The details of these are discussed in Unit 3 of this module.

Opolkm

Self-Assessment Exercise 1

Make a list of some techniques that can be useful in managing students' activities in the laboratory.



2.8 Summary

In this unit, we have studied:

What laboratory management Involves

The laboratory Management structure and plan execution process. Useful laboratory Management techniques Housekeeping and maintenance of the laboratory and Record keeping in the biology laboratory.



2.9 References/Further Readings/Web Sources

ES&H Program. Lawrence Livermore National Laboratory. Available at <http://www.ES&H Program. Htm>.

Mgbo, J. S., and Johnson-Ellis, F. (2015). *Cost-Reducing Strategies & Laboratory Management Techniques for Biology and Chemistry Teachers in the Gambia and Nigeria*. Available at <http://www.cost-reducing-stratagies and lab- smlgrtgambia .pdf>.
Maduabum, M.A (2013). *Teaching Integrated Science Effectively*, Onitsha: Space Matrix Publications Ltd.



2.10 Possible Answers to Self–Assessment Exercises

SAE 1

Some techniques for managing activities in the laboratory include:-

- i. Label all reagent bottles
- ii. Bottles containing volatile/toxic chemicals should be marked with red to indicate danger.
- iii. Each cupboard should bear a label
- iv. Ensure that gas cylinders are located outside the laboratory
- v. Ensure that items purchased are not obsolete

UNIT 3 SAFETY IN THE BIOLOGY LABORATORY

Unit Structure

- 3.1 Introduction
- 3.2 Learning Outcomes
- 3.3 Biology Laboratory Safety Regulations
 - 3.3.1 General Safety Principles
 - 3.3.2 Health and Hygiene
 - 3.3.3 House Keeping
- 3.4 Hazardous Operations
- 3.5 Hazards and Risk Assessment
- 3.6 Safe Handling of All Chemicals
- 3.7 Safety Equipment
- 3.8 Disposal Waste
- 3.9 Summary
- 3.10 References/Further Readings/Web Sources
- 3.11 Possible Answers to Self-Assessment Exercises



3.1 Introduction

Safety is a fundamental concern in all biology laboratory activities. Practicing good laboratory safety technique is one of the most important skills the students need to be a ware of in biology. Teachers and students must know and apply the necessary safety regulations in the storage, use and care of the materials used in laboratory activities. The unit examines the safety regulations in biology laboratory, hazardous operations, safety of equipment and disposal of waste in biology laboratory.



3.2 Learning Outcomes

By the end of this unit, you should be able to:

- List the safety regulations as they apply to biology laboratories
- Describe particular cautions that should be exercised before starting any experiment in the biology laboratory
- Make a list of the safety equipment and
- Describe how to use them in the biology laboratory.



3.3 Biology Laboratory Safety Regulations

3.3.1 General Safety Principles

The following safety regulations apply to all biology-teaching laboratories and have been established to minimize hazards and to maintain basic safety in the laboratory.

1. Smoking and eating in the laboratory are forbidden and in the demonstration areas. The storage and/or consumption of FOOD and DRINK in laboratories or areas where biological materials and/or chemicals are stored or used is prohibited. The Laboratory refrigerators or freezers should have this sign boldly marked on it: NO FOOD OR DRINK ALLOWED.
2. Be familiar with the location of emergency equipment -fire alarms, fire extinguishers and emergency eyewash and shower stations and know the appropriate emergency response procedures. Use equipment and hazardous chemicals only for their intended purposes.
3. Suitable footwear must be worn. Students and teachers should not be allowed in the laboratory or demonstration areas unless they are wearing suitable shoes as a protection from broken glasses and/or chemical spillages. In particular: bare feet, bathroom slippers or open -style shoes should not be allowed.
4. SAFETY GLASSES and face-protection are compulsory when volatile chemicals are to be used and must be worn at these times.
5. PROTECTIVE CLOTHING (popularly known as laboratory coat) should be worn for protection in case of fire or chemical spillage. This is usually a knee-length white coat, but for some hazardous operations, protection that is more elaborate may be required
6. Lab coats and protective gloves should be removed before leaving the laboratory. Do not use gloves when opening doors or answering the telephones. You could introduce chemicals or pathogens on these substances, thereby exposing others to hazards.
7. Long HAIR, or “attachment” or weave-on, and long-braids must be safely tied at the back before any laboratory activity.
8. Bags and other personal items must be stored under the benches in teaching laboratories and not between the benches.
9. Avoid practical jokes, distracting or startling other workers or students when they are handling hazardous chemicals.
10. Always inspect equipment for leaks, tears and damage before handling a hazardous chemical.
11. Study and identify the known hazards associated with the materials been used. Most importantly, never assume that all

hazards have been identified. Carefully read the labels before using any unfamiliar chemical

12. Always be alert *to* unsafe conditions and actions and call attention to them so that corrective action can be taken as quickly as possible.
13. Avoid tasting or smelling hazardous chemicals or any chemical for that matter. You should smell only substances on the instructions of your teacher
14. Avoid working alone in a building and do not work alone in a laboratory if the procedures being conducted are hazardous.
15. Unattended Operations: Leave lights on, place on appropriate signs on the door and provide for containment or toxic substances in the event of failure of a utility service.
16. Waste Disposal: Deposit chemical waste in appropriately labeled receptacles and follow all other waste disposal procedures. Do not discharge to the sewer concentration acids or bases, highly toxic substances that might cause structural damage or obstruct flow

3.3.2 Health and Hygiene

The following practices have been established to protect biology laboratory users (students, teachers, researchers and staff) from health risk associated with the use of hazardous chemicals:

- Do not use mouth pipette.
- Avoid direct contact with any hazardous chemical.
- Know the types of protective equipment available and use the proper type for each activity.
- Replace personal protective equipment as appropriate.
- Wash thoroughly with soap and water after handling chemicals, before leaving the laboratory and before eating or drinking.
- Be familiar with the symptoms of exposure for the chemicals, with which you work, and use the precautions necessary to prevent exposure

3.3.3 House Keeping

Safety follows from good housekeeping practices. The following guidelines should be used to maintain an orderly biology laboratory:

1. All work areas, especially laboratory benches, must be kept clear of clutter. All working surfaces and floors must be cleaned regularly.
2. No chemicals, model, etc. should be stored in hallways, stairways, floors or aisles, chemicals, items, specimens models not in active use should not remain on laboratory benches. Instead, place chemicals or items not in active use in appropriate storage area.
3. Access to all emergency equipment, showers, eye care etc should be free at all times.

4. All chemical containers must be properly labeled and the identity of the contents and the hazards made clear to users.
5. Spills made should be cleaned immediately and thoroughly
6. At the end of each work session, all chemicals and equipment's used should be placed in their assigned storage areas. The contents of unlabeled containers must be considered as waste and the user must properly place it in a labeled waste container
7. Biology safety committee should conduct regular formal and informal housekeeping inspection on biology laboratories.

3.4 Hazardous Operations

There are several potential hazards in the biology laboratory, these include:

- Explosive and other violent reactions
- Cuts
- Chemical splashes
- Eye accidents
- Fires
- Burns
- Corrosive agents
- Toxic and biology hazards
- Electrically powered laboratory apparatus
- Low temperature procedure
- Use of compressed gas cylinders

Physical hazards are from equipment.

These potential hazards can become real hazards by thoughtlessness, carelessness, haste, lack of knowledge and inexperience. The biology teacher and infact all laboratory users must be aware of the first aid treatment to administer to anybody that sustains an injury, or is exposed to any hazard.

3.5 Hazards and Risk Assessment

Before starting any work in biology, a risk assessment must be carried out. This should include the following:

- Every user must be familiar with, the layout of the laboratory, e.g. the location of the exits and their ease of access.
- location of safety equipment in the laboratory, e.g. the nearest fire blankets,
- sand buckets, fire extinguishers, emergency breathing equipment and first aid kits, etc.
- location of the main or emergency power switches. (There may be need to turn off the power in a hurry).

- dangers associated with the equipment or chemicals you will be using.
- waste disposal procedure for the products/chemicals you will be using.

3.6 Safe Handling of All Chemicals

Chemicals that are used routinely in the biology laboratory can be dangerous and must be used according to recommended practice.

Ascertain the correct handling procedure for all chemicals to be used and produced in the experiment. Then study to understand the science of what you are going to do before you start any manipulation. This will enable you prepare for any accident that might occur.

Examine each step of the proposed experiment and the potential hazards. Then acquire the necessary safety equipment.

Find proper procedures for safe disposal of all waste materials from the experiment.

Self-Assessment Exercise 1

All the answers are correct except one-

Before commencing work in the laboratory all users must be familiar with

- A. location of the safety equipment
- B. location of emergency exit and access
- C. location of the power switches
- D. Be aware of the dangers associated with the chemicals that will be used.
- E. Know the names all the chemicals in the laboratory.

3.7 Safety Equipment

The notion of safety equipment in the biology laboratory is to ensure that students, teachers, researchers who work in the laboratory are not injured or killed with the materials and equipment that they use during laboratory activities. Safety measures and procedures in biological activities should therefore be strictly maintained. The following safety equipments should be available in the biology laboratory.

Eye Wash Facilities

Eyewash facilities are required in all laboratories where injurious or corrosive chemicals are used or stored and should be easily accessible to the laboratory users. Biology laboratories that cannot afford wash

fountains can improvise with plastic squash bottles that can be operated by a quick release system that can simultaneously drench the eyes.

Eye Protection

Eye protection must be made available to students, teachers and all users of biology laboratory. Protective eye and face equipment must be used where there is a reasonable probability of injury from hazardous chemicals.

In a normal situation, the minimum acceptable requirements are hardened glass or plastic safety spectacles. The biology teacher should establish the level of eye protection needed per laboratory activities. The following are types of eye protection recommended for use in the biology laboratory:

Safety Goggles (Impact-Goggles)

This offers adequate protection against flying particles. This can be worn when working with glassware under reduced or elevated pressure or with drill presses or any other similar conditions. Safety Glasses with its side shields can offer minimal protection against flying fragments, chips, particles, sand and dirt. When a splash hazard exists, other protective eye equipment should be worn. Chemical Splash Goggles (Acid Goggles)

These are not common in Nigerian biology laboratories. They provide adequate protection against splashes as they have indirect venting for splash proof sides.

Chemical splash glasses offer the best eye protection from chemical splashes, when danger of a splash exists. Face shields these protect the face and neck from flying particles and splashes. Always wear additional eye protection under face shields especially when working with contagious bacteria or viruses.

Protection of Skin and Body

Protective clothing should be used to protect individuals working in the biology laboratories from chemical exposure. To determine the clothing needed for the chemical being used is not easy to obtain, as protective garments are not equally effective for every hazardous chemicals. Some chemicals will penetrate a garment in a very short time, whereas others will not. Therefore, the basic and most effective forms of protection are gloves and lab coats. When there is a reasonable anticipation of a splash, always protect exposed skin surfaces. Open-toed shoes, sandals and shorts should not be worn when working with injurious or corrosive chemicals. Even when there is minimal danger of skin contact with an

extremely hazardous substance, lab coats, coverall, aprons or protective suits should be utilized. These garments should not leave the work sites.

Spill Kits and Other Equipment

Every biology laboratory should have a standard clean up kits and other safety equipment. This should include the following: Waste containers

- Brooms
- Dusk pans .Mops
- Disposable thrash bags
- Mercury clean-up kit
- Bottle (acid) carriers
- Bonding and Grounding cables
- First Aid Kit

3.8 Disposal Waste

Hazardous wastes can be divided into three broad classes, namely:-

Chemical wastes (solids, liquids and gases)

Biological and special wastes (e.g. drugs, biological materials, animal and plant remains, etc.)

Radioactive wastes.

Each of these poses particular waste disposal problems. Procedures that reduce or eliminate the volume of wastes are encouraged, and when possible the smallest quantity of the materials can be used to reduce waste disposal. Animal remains should be buried and other chemicals properly disposed according to manufacturer's instructions.

Self-Assessment Exercise 2

Your students are to investigate the process of diffusion and osmosis in a model of a membrane system. Briefly explain how you will ensure safety in the laboratory.



3.9 Summary

In this unit, we have learnt that: safety is a fundamental concern in all biology laboratory activities. Both teachers and students must acquire and apply all necessary safety regulations in the biology laboratory.

Potential hazards in biology laboratory made hazardous through thoughtlessness, carelessness, haste, lack of knowledge and inexperience.

Risk assessment must be carried out before starting any work in biology laboratory.

Chemicals used routinely in biology laboratory, can be dangerous and must be used according to recommended practice. Safety equipment in the biology laboratory must be located before hand. They must be used and handled carefully. Waste from biology laboratory must be disposed of properly and carefully.



3.10 References/Further Readings/Web Sources

Ali, A. (2019). *Strategic Issues and Trends in Science Education in Africa*. Onitsha Nigeria: Cape Publishers International Limited



3.11 Possible Answers to Self –Assessment Exercises

SAE 1

Answer is - E. Know the names of the entire chemicals in the laboratory.

SAE 2

To ensure safety in the laboratory the students will be provided with the following items:-

Plastic safety spectacles to protect their eyes

Face shields to protect their faces from splashes

Overall aprons, lab coats and hand gloves to protect their skins/body from corrosive chemicals.

MODULE 4 EVALUATION IN BIOLOGY TEACHING

- Unit 1 Evaluation of Theory I (Objectives and Essay Questions)
- Unit 2 Evaluation of Theory II (Objectives and Essay Questions: Application, Analysis, Synthesis and Evaluation)
- Unit 3 Other Teacher Made Evaluation Procedures

UNIT 1 EVALUATION OF THEORY I (OBJECTIVES AND ESSAY QUESTIONS)

Unit Structure

- 1.1 Introduction
- 1.2 Learning Outcomes
- 1.3 Definition of Evaluation
- 1.4 Evaluating the Cognitive Skills
 - 1.4.1 Essay Type Questions
 - 1.4.2 Objectives Type Questions
- 1.5 The Six Categories of Cognitive Behaviour
- 1.6 Developing Test Items to Test the Various Categories
- 1.7 Summary
- 1.8 References/Further Readings
- 1.9 Possible Answers to Self-Assessment Exercises



1.1 Introduction

There are many important elements in a teachers teaching function. He prepares his lessons, introduces and develops it, and then he checks to see if his students have learnt what they are expected to learn. It is only after a teacher has confirmed that his students' have learnt what he has taught them that he will be comfortable to conclude his lesson.

The teacher is also concerned with making many decisions e.g. whether to continue to teach particular concept or whether to move on to another one, whether to adopt a new teaching method, discard an old one, who to promote. Who has done well in a course, etc. before a teacher can make any of the above decisions, he needs to assess his students, he needs to measure them, and he needs to evaluate them. It is the information he gets from this evaluation or assessment that will help him to take informed and appropriate decisions.



1.2 Learning Outcomes

By the end of this unit, you should be able to:

- Define Evaluation
- Describe how to evaluate the cognitive skills set essay and objective type questions
- List the six categories of cognitive behaviour
- Develop test items to test behaviour at the Knowledge level
- Develop test items to test behaviour at the Comprehension level.



1.3 Definition of Evaluation

As you read some books, you will notice that the terms tests, assessments, measurement and evaluation are used interchangeably. These terms are related since they all deal with checking for changes in behaviour of students because of teaching, but they have some minor differences. We will not be concerned with these differences now since you will have opportunity of learning about them in another course.

For our purpose here, we will define evaluation as a systematic process of determining the extent to which students achieve educational objectives. This definition has two important aspects. One is that evaluation involves a systematic process, which does not include casual uncontrolled observation of pups. Second, evaluation always assumes that educational objectives have been previously identified. Without previously determined objectives, it will be extremely difficult if not impossible to judge the extent of progress. (It will just be like someone leaving his house to go somewhere without a destination in mind, the person will not know when he/she gets to his/her destination).

1.4 Evaluating the Cognitive Skills

Evaluating the cognitive skills generally involve the use of paper and pencil tests. However these assessments can also be done on computer systems. Two types of paper and pencil tests are generally used. These are the essay and objective type questions.

1.4 .1 Essay Type Questions

These are questions requiring students to write down their answers. Essay questions are usually of two types. One is the short answer type, e.g. when you ask a student to explain using three sentences the meaning of photosynthesis. The second type of essay is the extended response

format e.g., when you ask a student to give a detailed account of the process of photosynthesis. The difference in the two formats is that in the short response format, you are restricting the student to a few sentences or lines, while in the extended response format, there is no page restriction and the student is free to write as much as he/she wants.

1.4.2 Objective Type Questions

Objective type questions require students to choose answers from a given list or to supply one-word answers. They are of many forms and we will look at some of them. The most common form of objective type questions is the multiple-choice question. This involves asking a question or making a statement and giving a number of response options from which the student is expected to pick the correct one. Another form of objective type question is making a sentence and leaving out a key word in the middle or at the end of the sentence and then asking the student to supply the word to in the gap. It could also be in the form of making two lists A and B and asking students to match statements from the two lists.

Let me give you some examples and allow you to give some more.

Example 1: One of the under listed is not a class of food

- a) Fat
- b) Protein
- c) Carbohydrate
- d) Milk

Example 2: What part of the nose is responsible for smell?.....

Example 3:is the movement of solvents across a semi-permeable membrane.

Example 4: In a food chain.....is the primary producer?

Self-Assessment Exercise 1

Using the topic, Living and non-living things, construct

1. Two essay type questions
2. Two objective type questions

1.5 The Six Categories of Cognitive Behaviour

For you to evaluate meaningfully in Biology, you must take care of the various mental and intellectual skills, which learners are supposed to acquire. These skills have been classified into six by Bloom (1956). We

will briefly look at the meaning and expectations in each of these categories before looking at how to evaluate them.

In this section, you will read about each category, and get a brief description of what each category stands for.

Knowledge - this refers to those behaviour and test situations which emphasis the remembering by either recognition or recall of ideas, materials or phenomena e.g., how many legs have a cockroach?

Comprehension - refers to those behaviour or responses that represent understanding of the literal message contained in a communication, that is, ability to give an explanation not a definition e.g. explain the process of photosynthesis.

Application - This is the ability to apply the appropriate abstraction without having to be shown how to use it in that situation e.g. given a biological principle and appropriate environmental conditions, the student should be able predict the result.

Analysis - this emphasizes the breakdown of a material into its component parts and the detection of the relationships of the parts and of the way they are organized.

Synthesis - this is the putting together of elements and parts so as to form a whole, that is, working with elements, parts etc., and combining them in such a way as to constitute a pattern or structure not there before.

Evaluation - this is the making of judgment about the value for some purpose of ideas, works, solutions, methods, materials etc. It involves the use of criteria as well as standards for appraising the extent to which particulars are accurate, effective, economical or satisfying.

(You will see examples of these three categories when we look at how to set test items to assess them).

1.6 Developing Test Items to Test the Various Categories

Knowledge - This is an area of evaluation, where most teachers do not have problems. Most questions that teachers ask belong to this category. We will not waste too much time on them because, I am sure that you can ask millions of questions that will test this domain. I will give you some examples, and then allow you to give some more examples.

Examples

1. How many legs has a cockroach?
2. Which part of a leaf is involved in photosynthesis?

SELF ASSESSMENT EXERCISE 2

Set two questions under the topic NUTRITION, that will measure at knowledge level. (One example is given to you-how many classes of food do we have?)

Comprehension –

Comprehension items should aim at finding out whether or not the students understand the biological concepts studied; whether they can give an explanation, not a definition.

While knowledge may imply that students can recall or recognize a concept, comprehension implies in addition a thorough or reasonable familiarity with the concepts. What this means is that when you state a fact or principle using other words or in unfamiliar circumstances, your students should be able to understand it.

In setting questions that will test for comprehension, you can use both the essay type and objective type of questions. You must however, ensure that your questions meet some important criteria and observe some conditions for the effective use of questions in evaluating at the comprehension level.

1. Ability to select the best explanation of a biological concept from a list of explanations.

An example of a question that meets these criteria is given: Which of the following would you say is a good explanation of the process of photosynthesis?

- A. It is the whole process by which the simple inorganic raw materials are converted into complex substances of which the green plant is composed.
- B. It is the process of making fats, oils, and proteins in the green leaves of a plant during sunlight, with water and carbon dioxide as raw materials.
- C. It is a chemical reaction that takes place in the green parts of plants resulting in the formation of simple sugars and oxygen D. It is the reaction between food substances like glucose with oxygen, resulting in the formation of water, carbon dioxide and energy.
- D. It is the conversion of the glucose or simple sugars manufactured in the leaves into starch and cellulose for storage. Within the five alternative responses in this item, the main components of photosynthesis - energy, green leaves, water, carbon dioxide, oxygen, and simple sugars have been included in all forms of

order that do not all constitute photosynthesis. Understanding of the term would imply ability to relate each of the components mentioned to the others to be able to arrive at the correct answer.

In an essay form, you may ask the student to explain the process of photosynthesis. His answer may be a recall of a previously learned explanation and so is not likely to discriminate between those students who comprehend and those who merely recall the concept.

2. Ability to criticize an inadequate definition or explanation.
Example: Criticize the following definition:

A reptile is an animal which does not suckle its young ones and which lives on land.

Obviously, this is neither a good definition nor an explanation of the term "reptile". To answer it adequately requires that the student have an adequate or more plausible understanding of what a reptile is. This understanding will enable the student point out that there are many animals which do not suckle their young and which cannot be classed as reptiles. In addition, there are many land animals, which are not reptiles

3. Ability to draw and label important structures of plants and animals.

Example: make a diagram of the cross-section of a dicotyledon stem, and label the following parts: pith, cortex, xylem, phloem and epidermis.

The question requires the student to show that he knows the relative sizes and relative positions of the structures involved, as well as being able to label certain structures. A good diagram, which is well labeled is as good evidence of understanding as a page or more of written description and explanation.

4. Ability to associate a given structure(s) in a given diagram with various functions, and ability to associate a given function(s) in a diagram with a part or parts of the diagram. Example 1: In the diagram provided (diagram is the longitudinal section of a dicot leaf), what is the function of the part labeled C? (C consists of a group of spongy mesophyll cells).

1. Proteins are manufactured here.
2. Starches are converted to simple sugar.
3. Carbon dioxide is absorbed from the atmosphere.
4. Manufactured food is stored for later use.
5. Glucose is manufactured in this section.

Here the student has to associate a given structure (not named, but given an alphabetic label) with a number of functions. It involves both naming the structure, (even though the student may not write it down), and knowing its function to the organism and therefore rejecting any other answer (in a multiple choice form) which does not fit.

Example 2: In what structure in the diagram provided is excess water got rid of. (Same diagram as in example 1).

1.A 2.G 3.F 4.D 5.B

Here the reverse mental process takes place. The student thinks out the name of the structure, which performs that function, and then tries to identify this structure in the diagram provided.



1.7 Summary

In this unit, we have learnt that:

- i) Evaluation is a systematic process of determining the extent to which students achieve educational objectives.
- ii) Evaluating the cognitive skills generally involve the use of paper and pencil tests.
- iii) Two types of paper and pencil tests are generally used. These are the essay and objective type questions.
- iv) The six categories of cognitive behaviour are Knowledge, Comprehension, Application, Analysis, Synthesis and Evaluation.
- v) Developing test items to test the various categories requires various skills and techniques.



1.8 Reference/Further Readings/Web Sources

Aliyu Abdullahi (2018). *Science Teaching in Nigeria*: Atoto Press, Ilorin.

Ali Anthony, (2016). *Strategic Issues and Trends in Science Education*, Onitsha: Africa Cape Publisher International Limited. Visit www.study.com.



1.9 Possible Answers to Self-Assessment Exercises

SAE 1

Two Essay Questions-

- 1 –Discuss the characteristics of living things
- 2-Using specific examples describe the process of respiration in living things.

Two Objective Questions-

- 1 Which of these is not a characteristic of living things?
 - A. Respiration
 - B. Nutrition
 - C. Locomotion
 - D. Reproduction
 - E. Duplication

- 2 ----- is a characteristic of living things.

SAE 2 -- Questions at the knowledge level

- 1 Discuss the two types of nutrition in living things
- 2 What are the different modes of nutrition in living things?

UNIT 2 EVALUATION OF THEORY (OBJECTIVES AND ESSAY QUESTIONS: APPLICATION, ANALYSIS, SYNTHESIS AND EVALUATION)

Unit Structure

- 2.1 Introduction
- 2.2 Learning Outcomes
- 2.3 Testing at Higher Cognitive Levels
 - 2.3.1 Application
 - 2.3.2 Analysis, Synthesis and Evaluation
- 2.4 Conclusion
- 2.5 Summary
- 2.6 References/ Further Readings/Web Sources
- 2.7 Possible Answers to Self-Assessment Exercises



2.1 Introduction

In this unit, we will continue from where we stopped in unit 1 of this module. We will look at how to set objective and essay type questions that can be used to assess learning outcomes in the higher cognitive processes of Application, Analysis and Synthesis.



2.2 Learning Outcomes

By the end of this unit, you should be able to:

- give the conditions under which good application questions can be set
- write test items that will be used to assess learning at the application level.



2.3 Testing at Higher Cognitive Levels

2.3.1 Application

Testing/Evaluating for application requires asking students' questions that will make them use biological information in different ways other than the ways in which they were taught in class. Some examples are given: Given a biological principle and appropriate environmental condition (natural or experimental), the students may be required to predict the result. Given the environmental condition and their effect on

the biological system in question, the students may be requested to deduce the underlying biological principle.

Given the biological principle or principles and the results, the students may be requested to deduce what environmental conditions may have given rise to the results.

The following three examples will be given to guide you. All three are centered around the principle of Osmosis. (The principle of Osmosis holds that if two solutions of different concentrations are separated by a semi-permeable membrane, there will be a movement of solvent from the weaker solution to the stronger solution as long as the difference in concentration persists.)

Example 1: To the end of a thistle funnel, a piece of sheep's bladder was securely tied. Strong salt was poured into it and it was stood upright in a beaker of water. What will happen to the level of water in the funnel a few hours later?

In this question, the conditions of the experiment have been given and the student is expected to use the information to predict the results. The principle of Osmosis is implied, rather than stated.

Example 2: To the end of a thistle funnel, a piece of sheep's bladder was securely tied. Strong salt was poured into it and it was stood in a beaker of salt solution. After an hour, it was found that the level of liquid in the beaker had dropped. What can you conclude about the concentrations of the salt solutions used in this experiment?

The principle of Osmosis is again implied and the result given. The student is expected to deduce the most probable experimental condition that would produce the given results.

Example 3: A fresh water protozoan animal was dropped into a beaker of seawater. Three minutes later, it was examined under the microscope and was found to have shriveled. How would you explain this?

The experimental conditions and the results are given and the student is required to cite the appropriate principle involved and use it in explaining the results. The principle is Osmosis.

It is necessary in Examples 1 and 2 to ensure that if the principle is not stated, it is sufficiently implied, otherwise, there will be no answer to the question or there will be no unique answer to the question. In developing application questions, therefore, care must be taken to avoid

some mistakes that could render the questions invalid. Some of these situations are:

The situation used in the question must be real, that is, not fictitious. You must resist the temptation of building items in which the concepts involved are not real. An example of a question that is using a situation that is not real and therefore unacceptable is:

- Suppose that for an unknown reason, all the plants of the earth died. What would be the source of food for the animals left on earth?
- The question might be acceptable if one is testing for reasoning ability, but it is definitely not acceptable in a biology class.
- The second thing is to ensure that the question asked is testing reasoning in a biological principle and not student's intelligence.

SELF ASSESSMENT EXERCISE 1

Look at the two examples below and pick the one that is testing reasoning in a biological situation.

Example 1: A gardener acquired a new plot of land where he planted onions, tomatoes, and lettuce. For several years, the yield from the onions was very poor, so he stopped gardening the soil. A year later, he resumed with the same three plants. Which of these would produce the poorest crop?

Example 2: What would be the effect on a mammal, if the hepatic portal vein were ligatured?

Example 2 is a better question because it requires that the student know the functions of a hepatic portal vein. If he/she does not know this, he/she will be unable to reason that though the animal may eat and digest food, the digested food does not get to the liver for storage, and that the liver will run short of food, etc.

The next thing to note is that the situation used in asking the question must be new to the students. This means that the situation being described is not one that was used for the students before; otherwise, it will be an ordinary knowledge question since all the students' need will be to remember what has been said earlier. This poses a big problem. How can the biology teacher continue to construct such questions for each time an application question is given, it loses its novelty and upon subsequent administration, the teacher cannot know whether the responses given are products of reasoning or of memory? There does not appear to be much that the biology teacher can do other than to keep thinking up new scenarios each time he/she wants to ask application questions.

SELF ASSESSMENT EXERCISE 2

Using the three principles guiding setting questions at the application level, set two questions that can be used to assess application.

2.3.2 Analysis, Synthesis and Evaluation

The components of reasoning known as analysis, synthesis and evaluation are usually not exhibited singly. In a classroom situation, it is extremely difficult to look at a student and say that he/she is operating at either the analysis, synthesis or the evaluation level. These processes are therefore referred to as higher cognitive skills. The typical biological or scientific problem requires mental activity in all the six categories of cognition. Yet, it is easy to isolate the first three and test them. That is why the last three are lumped together and test items developed to test them.

We will now give some examples of items that can be used for the higher cognitive skills.

Example 1

An SS 1 student wanted to demonstrate to her parents that air is necessary for germination. She did not have the usual biology apparatus at home for this experiment, so she improvised with some materials from her home. She first soaked some cotton wool in water, put it on a saucer, and placed a handful of beans on it. Then she put a similar quantity of beans in a small milk jug, and poured palm vegetable oil over it. The beans in the saucer and the jug were all healthy. Both saucer and jug were placed together on a sheet of glass covered with a large glass bowl, the edges of which were smeared with Vaseline. Results: A few days later, most of the beans in the saucer germinated while none of the beans in the jug germinated. Two days after germination, all the germinated seed withered and died.

Answer the questions 1-4 based on the report of the experiment. 1. What conclusion can you reach from the experiment?

- a) It clearly demonstrates that air is necessary for germination
 - b) It does not show whether or not air is necessary for germination.
 - c) It does not in any way demonstrate that air is necessary for germination
2. What is your reason for choosing the answer to question?
- a) Some of the seeds in the saucer did not germinate. b) None of the seeds in the cooking oil germinated.
 - c) The cooking oil contains no water.
 - d) All the germinated seeds died two days after germination.

- e) The apparatus does not come from the biology laboratory, and so the experiment is not scientific enough.
3. What could have caused the death of the germinated seeds?
- a) Lack of oxygen in the bowl chamber.

We will now give some examples of items that can be used for the higher cognitive skills.

Example 1

An SS 1 student wanted to demonstrate to her parents that air is necessary for germination. She did not have the usual biology apparatus at home for this experiment, so she improvised with some materials from her home. She first soaked some cotton wool in water, put it on a saucer, and placed a handful of beans on it. Then she put a similar quantity of beans in a small milk jug, and poured palm vegetable oil over it. The beans in the saucer and the jug were all healthy. Both saucer and jug were placed together on a sheet of glass covered with a large glass bowl, the edges of which were smeared with Vaseline.

Results: A few days later, most of the beans in the saucer germinated while none of the beans in the jug germinated. Two days after germination, all the germinated seed withered and died.

Answer the questions 1-4 based on the report of the experiment.

1. What conclusion can you reach from the experiment?
 - a) It clearly demonstrates that air is necessary for germination
 - b) It does not show whether or not air is necessary for germination.
 - c) It does not in any way demonstrate that air is necessary for germination
2. What is your reason for choosing the answer to question?
 - b) Some of the seeds in the saucer did not germinate. b) None of the seeds in the cooking oil germinated.
 - f) The cooking oil contains no water.
 - g) All the germinated seeds died two days after germination.
 - h) The apparatus does not come from the biology laboratory, and so the experiment is not scientific enough.
3. What could have caused the death of the germinated seeds?
 - a) Lack of oxygen in the bowl chamber.
 - b) Increase in temperature of the bowl chamber. c) Absence of sand in the saucer.
 - d) Exhaustion of reserved food in the cotyledons. e) Both (a) and
4. Suppose the Vaseline seal was leaking, how right would it be to say that all the beans in the saucer would have germinated?
 - a) Definitely right b) Probably right c) Uncertain
 - d) Probably wrong

e) Definitely wrong.

Example 2

In a class project, the following experiment was set up : A test tube each of a freshly prepared lime water was put into five bell jars A,B,C,D and E. Into A, a potted mushroom was put;

Into B, a young garden plant was put; Into C, a frog was put; Nothing was put into D.

C and E were put away in the dark, while the others A, B, and D were left in bright sunlight. The experiment was allowed to stand for many hours.

Represent what has been described in a diagram/sketch. Study it carefully and use it to answer questions 1-3.

1. To illustrate that animals respire both in daylight and night, it will be sufficient to use the results of the following test tubes: a) C and D b) C and E c) A and C d) B and C
 - e) None of the above.
2. In which of the bell jars was oxygen content increased at the end of the experiment?
 - a) E b) B c) C d) A and D
 - e) None of the above.
3. To illustrate that respiration takes place in green plants in both daylight and night, it will be sufficient to use the results of the following test tubes:
 - a) D and E b) B and E c) E only d) B only
 - e) A and E.



2.4 Summary

In this unit, we have studied that Testing/Evaluating for application requires asking students' questions that will make them use biological information in different ways other than the ways in which they were taught in class.

The typical biological or scientific problem requires mental activity in all the six categories of cognition. Yet, it is easy to isolate the first three and test them.

It is not so easy to isolate Analysis, Synthesis and Application, that is why they are lumped together and test items developed to test them.



2.5 References/Further Readings/ Web Sources

Aliyu Abdullahi (2016). *Science Teaching in Nigeria*: Atoto Press, Ilorin.

Ali Anthony, (2018). *Strategic Issues and Trends in Science Education*, Onitsha: Africa Cape Publisher International Limited.

Zimmerman, Corinne; Croker, Steve (2014) *Journal of Cognitive Education and Psychology. A prospective Cognition Analysis of Scientific Thinking and the Implications for Teaching and Learning* Vol 13, No 2, 2014 pp. Springer Publishing Company.

Edward W. Sarath (2013) *Improvisation, Creativity and Consciousness*: Sunny Press p. 487.



2.6 Possible Answers to Self-Assessment Exercises

SAE 1

Example 2 is a better question for testing reasoning in the situation given above.

SAE 2

Two questions assessing application level-

1. If you were to add pure water to a plant, what type of situation would you create?
2. Insulin is a hormone that serves as a signal to tell cells to absorb glucose. What would happen if the receptor for insulin is damaged?

UNIT 3 OTHER TEACHING MADE EVALUATION PROCEDURES

Unit Structure

- 3.1 Introduction
- 3.2 Learning Outcomes
- 3.3 Evaluating the Psychomotor Domain
 - 3.3.1 Procedures and Products
 - 3.3.2 Performance Tests
 - 3.3.3 Procedures
 - 3.3.4 How to Evaluate Procedures and Products
- 3.4 Affective Domain
 - 3.4.1 Type of Affective Measure
- 3.5 Evaluation of Practical Biology
 - 3.5.1 Manipulative Skills
 - 3.5.2 Skills in Observation and Accurate Recording of
 - 3.5.3 Ability to Interpret Results
 - 3.5.4 Ability to Plan and Execute a Project
- 3.6 Evaluation through Projects
- 3.7 Summary
- 3.8 References/Further Reading/Web Sources
- 3.9 Possible Answers to Self-Assessment Exercises



3.1 Introduction

The primary way that teachers obtain data concerning their students' attainment is by their daily contacts with the students. Teacher observations of daily behaviour and the tests they give constitute the major impact upon teacher evaluation of students' achievements. There are certain aspects of classroom work that cannot be tested with the conventional paper and pencil test but with other techniques. Such practical activities abound in biology. In this unit, we will study such other evaluation techniques that you need as a biology teacher in evaluating your learning outcomes.



3.2 Learning Outcomes

By the end of this unit, you should be able to:

- Distinguish between procedures and products in academic achievement
- Describe performance tests
- Describe procedures and processes using a biology topic,
- Describe how to evaluate procedures and products

- Describe how you will evaluate the psychomotor skills
- Discuss the affective skills that can affect the success of your teaching
- Identify instruments you can use to evaluate affects
- List the aspects of a practical work you will assess using a biology topic,
- Design a rating scale you will use to assess a given practical exercise
- Design a rating scale you will use to evaluate projects.



3.3 Evaluating the Psychomotor Domain

3.3.1 Procedures and Products

In biology teaching, we are not always interested in evaluating what a person knows. Our interest sometimes goes beyond this to measuring what the person can do. What a person can do requires both an instrument (Performance test) and a procedure.

3.3.2 Performance Tests

These techniques try to establish what a person can do as distinct from what he knows. Work samples and skill samples can tell us this. We are also interested in the tasks involved in making, producing or creating the product so that we will be able to diagnose weaknesses in the instructional system, the learning process, or both.

3.3.3 Procedure

This refers to the steps followed in doing some task. The biology student is expected to be able to manipulate a microscope or observe something placed under the microscope, depending on his level. He should be able to draw and label a given specimen, and he should be able to set up a simple experiment, example one to demonstrate the conditions necessary for germination. Although procedures and products are inter-related, they are generally separate entities that can be observed, measured, and evaluated independently. In some areas, it might be more desirable to rate procedures during the early phases of learning, and products later, after the basic skills have been learnt. Example in a biology class, as soon as a student starts assembling the materials he/she will use to set up an experiment, it is possible to evaluate whether she is assembling the right materials. From here, you can check whether she is setting them up in the right way. It is only at the end that you can look at the' whole set-up and the student's write up. Yet all the processes that go before are as important as the finished work.

Process evaluation is also very important in the affective domain. Observation of a student while he is performing a task can provide useful information concerning his attitude. All evaluation requires that some criterion of correctness be established before hand by the evaluator. For procedural evaluation, our concern should be with efficiency and accuracy.

For example, to ascertain whether students can operate a microscope, the teacher would first list out the steps involved and then observe every one student to see how well these steps were followed. For accuracy, the teacher might use as a criterion, the precision with which the slide is focused.

3.3.4 How to Evaluate Procedures and Products

To evaluate a procedure or product, we must first observe the procedure being used or the product made by the student. Then using some form of scale, we determine the degree to which the steps were followed or the product made is acceptable. The scales that we can use include:

- Check lists
- Rating scales, and
- Ranking method.

After identifying the criteria to be used, the teacher must be satisfied that the criteria are related to the instructional objectives. For example, if your objective states that at the end of the lesson, the students should be able to set up an experiment to show the conditions necessary for germination, the criteria should not include asking students to draw and label, but should concentrate on the dexterity with which the students are able to set up the experiment.

The weight assigned to each step or characteristic should reflect the instructional emphasis placed on each criterion. The teacher will then assign some numerical value to each component so that at the end, he/she will be able to determine who performed better than the other .

Self-Assessment Exercise

1. Distinguish between procedure and process in assessment.
2. Choose a biology activity, identify the procedure in the activity, and state how to evaluate each.

3.4 Affective Domain

Affective measures are non-cognitive measures which can be used to assess the emotional status of students in various contexts. Affective measures are important in educational assessment because all forms of learning can only be meaningfully done in within adequate contexts of feeling, attitudes, interests, aspirations, and so on. These feelings are generally described as affects and the affective disposition of a student has direct relevance to his/her attitude towards the value of an educational activity.

3.4.1 Types of Affective Measures

There are many types of non-cognitive tests. These include assessment tools such as:-

- anecdotes checklists
- sociometric techniques interviews
- rating scales, attitude scales questionnaire, interest inventory, Self-concept scales, etc.

The test may be structured in a form where respondents have a limited number of alternative responses to choose from, or it test may be unstructured in a form where they are free to respond in the way they like.

Biology teachers can use some of the already prepared attitude and interest inventory to assess students. These type of assessment will enable them know where to pitch their teaching.

3.5 Evaluation of Practical Biology

One of the distinguishing features of science, of which biology is one, is its characteristic technique and skill for exploring nature. The abilities which enable both science teachers and students to engage in a meaningful scientific investigation including the ability to observe, communicate, identify problems, ask questions formulate hypothesis, design experiments, control variables, analyze data, make inferences and predictions. The assessments of these skills are usually based on the qualities to be tested. These are-

- a. manipulative skills
- b. skill in observation and accurate recording of observations
- c. ability to interpret results of planned experiments
- d. ability to plan and carry out experiments

3.5.1 Manipulative Skills

Assessment of these skills should be based on direct observation of pupils when they are doing their laboratory work and the things to look out for include:

- -efficient use of working tools
- -use of correct operational sequence
- -ease of operation based on limited instructions correct handling of apparatus
- -successful completion of an experiment orderliness

3.5.2 Skills in Observation and Accurate Recording

Emphasis here should be on the ability of students to: record observations correctly including actual drawing as against textbook specimen, observe accurately, read instructions correctly

3.5.3 Ability to Interpret Results

Here the things to look out for are student's ability to: understand the theory underlying generalizations or principles being investigated drawing of logical conclusions from the findings of an experiment

3.5.4 Ability to Plan and Carry out an Experiment

Students will be assessed on the following attributes:

- ability to choose appropriate equipment and apparatus,
- ability to organize or assemble apparatus/equipment chosen
- suitability of experimental technique chosen.

3.6 Evaluation Through Projects

When we use projects, we are able to measure both cognitive and affective learning as psychomotor skills.

The following guidelines have been found useful in evaluating projects in biology.

1. Background information is how well the students have shown mastery of the concepts and principle underlying the projects they are about to execute
2. Design of the experiment preparation of materials.
3. Manual skills and use of appropriate experiment techniques.
4. Recording and presentation of findings.
5. Discussion and explanation of findings.

Each of the attributes can be scored on a five-point scale as follows:

Excellent = 5

Very Good = 4

Good = 3

Fair = 2

Poor = 1

In that way, the maximum score per project will be 25, while the minimum will be 5.



3.7 Summary

In this unit, we have learnt that: -procedures and products are inter-related. They are separate entities that can be observed, measured and evaluated independently. Procedure or product can be evaluated by first observe the procedure being used or product made by the earner using the following scales checklists, rating scales and ranking method.

Affective are non-cognitive measures which can be used to assess the emotional status of students.

Assessment tools used for non-cognitive tests are anecdotes, checklists, sociometric techniques, interviews, rating scales, attitude scales, questionnaire, interest inventing and self-concept scale.

SELF-ASSESSMENT EXERCISE 2

Evaluation of practical skills in biology are based on the following except-

- A. Manipulative Skills
- B. Ability to carry out experiments
- C. Ability to interpret results of experiments carried out
- D. Ability to draw the equipment used for the experiment
- E. Skill in observation and accurate recording



3.8 References/Further Readings/Web Sources

Zimmerman, Corinne; Croker, Steve (2014) *Journal of Cognitive Education and Psychology. A prospective Cognition Analysis of Scientific Thinking and the Implications for Teaching and Learning* Vol 13, No 2, 2014 pp. Springer Publishing Company.

Aliy Abdullah (2016). *Science Teaching in Nigeria*: Atoto Press, Ilorin.

Ali Anthony, (2018). *Strategic Issues and Trends in Science Education*, Onitsha: Africa Cape Publisher International Limited.



3.9 Possible Answers to Self-Assessment Exercises

SAE 1

Procedure is a set of instruction for completing a task, the order or sequence of the steps to be followed to make something happen.

While Process is a series of tasks and activities that produce results or outcomes.

1. The Chosen Activity is - Examining the parts of Flower
2. The procedure in examining the parts of a Flower include-
 - Use a razor blade to remove the corolla tube
 - Cut the style and stigma away
 - Use a blade to remove the ovary
 - Cut the ovary along the vertical plane
 - Use hand lens to examine the cut surface

To evaluate the procedure a 5point rating scale will be used as shown below-

Rating Scale –

- 5points (Pass) -Excellent
- 4points (Pass) - Very Good
- 3points (Pass) - Acceptable
- 2 points (Fail) - Weak

The total maximum score will be 25 marks.

SAE 2 Answer - D. Ability to draw the equipment used for the experiment.